

Hydraulic clutch conversion kit Instruction manual

Product number 15-02-0002

Adaptation model CT125 (JA55-1000001 ~)

Thank you very much for purchasing our products.

Thank you so you will comply with the following matters at the time of use. Before installation, please check your always kit contents. If there is a point of notice event, Please contact us the dealer of purchase.

◎ If the description, such as photos or illustration different with this part.

☆ Please read carefully before use ☆

◎ The use of ignoring the instructions that are written in the instruction manual, if an accident or damage has occurred, we can not assume any responsibility for compensation.

◎ This product installation and use, when a problem occurs to after market goods, guarantee other than this product, also can not assume any in any such matters.

◎ If it was the case or mounting that has been processed like a product, it will not be covered under warranty.

◎ It is not possible to inquire of the combination of other manufacturers.

◎ This product is the above-mentioned vehicle exclusive goods. Is not possible attached to the other vehicle. Please note.

◎ Product may have edges or protrusions. Be sure to wear working gloves.

(Please wear work gloves when working, even if a photo in this article show without work gloves.)

◎ This product does not change the transmission itself. The shift pattern will be the same as stock (N → 1 → 2 → 3 → 4).

◎ Since there is no oil pod window in the L. master cylinder attached to the kit, please check the amount of the brake fluid by the upper limit line on the inside of the container.

◎ Anodic oxide coating products there is a case in which fading occurs in color aging. Please note.

◎ In addition, this manual and genuine service manual are intended for those who have a basic skills and knowledge.

If no experience of mounting, etc., who preparation of such a tool is insufficient, we recommend that it is your request to the shop with a technical credit.

◎ When using with TAKEGAWA Knuckle Guard 09-11-0240 with this kit u will need to use bracket kit (09-11-0347) same time.

◎ For non-reusable parts not included in this kit, please prepare new genuine parts yourself.

~ feature ~

This products has automatic centrifugal clutch on the primary side, to make possible clutch operating when starting and stopping as automatic centrifugal clutch. But it become the manual clutch operating when you riding other than that.

You can enjoy the manual shifting motorcycle with the clutch lever.

Parts that can be installed at the same time

○ Master cylinder guard:06-08-3031/06-08-3032/06-08-3033

○ Knuckle guard:09-11-0346

○ Aluminum billet lever (foldable):02-01-0269

⚠ Caution When the handling of ignoring this display, property damage and human shows the assumption of what injury.

■ When performing the work, it should be made to prepare the tools for the job. (Breakage of parts, it may cause injury.)

■ Do the work must always specified torque using a torque wrench. (Damage of bolts and nuts, and cause of dropout.)

■ The product and the frame, might have edges or protrusions. When working, please wear work gloves to protect your hands. (It may cause injury.)

■ Be sure to each part inspection before operation, check the loosening of the threaded portion, be sure to securely tighten the specified torque if there is loose. (It may cause detachment of the parts.)

■ Gasket always use new parts. Also, parts can be re-used may be checked, if wear or damage, it is always replaced with new parts.

■ Be careful that the brake fluid does not contact your skin. After work, wash your hands thoroughly with water. (Otherwise, you will have a rough skin.)

■ Please use the specified brake fluid. Do not use different brands of brake fluid. (May cause problem or failuer.)

⚠ Warning When the handling of ignoring this display people died, shows the contents of the serious injury possibility is assumed.

■ The technology and those who no knowledge, please do not to work.

(The cause of parts damage etc., could result in falls and accidents.)

■ If you start the engine, be sure in a well-ventilated place. In the sealed such place, please do not start the engine. (There is a risk of carbon monoxide poisoning.)

■ During operation, when an abnormality occurs, immediately stop the vehicle in a safe place, please stop running. (It may lead to an accident.)

■ When performing the work, do the work safely stabilize the vehicle in a horizontal location. (There is a risk of injury vehicle collapsed while working.)

■ Inspection, maintenance, the instruction manual or, inspection methods such as service manuals, to protect the way, should be done correctly. (unsuitable inspection and maintenance, there is a risk that result to an accident.)

■ When carrying out the inspection and maintenance, etc., if found damaged parts, replace the damaged parts to avoid possible to reuse the parts. (There is a risk that lead to accidents Continued use.)

◎ Please note. Performance up, the design change, the product and the price in the cost up, etc. are subject to change without notice.

◎ Please be informed that we shall be held harmless against any claim against us whatsoever arising out of use of the products in racing and the like.

◎ Keep this manual stored until this product is discarded.

SPECIAL PARTS
TAKEGAWA

CONTACT Address : 3-5-16 Nishikiorihigashi Tondabayashi Osaka JAPAN

TEL: +81-721-25-1357 FAX: +81-721-24-5059 e-mail: english@takegawa.co.jp URL http://www.takegawa.co.jp

Please contact with your name and country name provided. (Only English please)

Product content

00-02-0501

※⑦⑧ are different materials.
Do not mix it when out of
the bag.

00-02-0509

00-00-2893



Number	Product content	Quantity	Item Number
1	Clutch release cylinder	1	_____
2	O-ring, 8mm	1	00-02-6218 (3 pcs)
3	Cable ties, 150mm (Black)	3	00-00-0135 (10 pcs)
4	O-ring, 12.5mm	1	00-02-6219 (4 pcs)
5	Stainless steel shim ring, $\Phi 10.2 \times \Phi 22 \times 1.5$	1	00-02-6220 (2 pcs)
6	Release piston ($\Phi 33$)	1	_____
7	O-ring, 30mm (NBR)	1	00-00-0674 (4 pcs)
8	O-ring, 30mm (SBR)	1	00-00-0673
9	Clutch lifter rod ($\Phi 17/L:9\text{mm}$)	1	00-02-0510
10	Clutch release spring	1	00-00-1688
11	Aluminum sealing washer, 10mm	4	00-00-0789 (5 pcs)
12	Breeder cap	1	00-00-2436
13	Breeder screw	1	00-02-6213
14	Air-free banjo bolt	1	_____
15	Banjo bolt (SUS/M8/L:38)	1	00-02-0508 (With sealing washer 2 pcs)
16	Slim line banjo (straight)	2	00-07-0006
17	Clutch master cylinder (Mirror size 10/ $\Phi 11\text{mm}$ /Black lever)	1	02-02-2107
18	Brake hose (1160mm)	1	00-06-0221
19	Cushion, 15x140x5	1	00-00-0299
20	R.Crankcase cover gasket	1	00-02-0356

※Please order in the repair parts are always repair part number.

If it is not the part number order, you may not be able to order. Please be forewarned.

It should be noted, In the case of parts that can not be separately shipment, please order a set part number.

■ Mounting procedure ※ Please refer to the Genuine Service Manual for detailed mounting methods and specified torques that are not specifically described.

○ Use main stand and up position when work with the vehicle.

□ Installation of clutch master cylinder

○ Remove the Left side mirror and adapter.

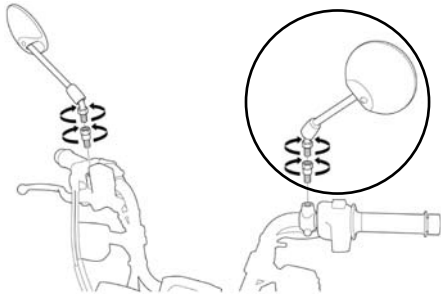

○ As the diagram, remove the steering handle weight, Left grip rubber, handle switch assembly and mirror holder.
(Mirror holders will not be reused.)

※ Left grip rubber will be reused. If grip adhesive used, clean the inside of the grip on the steering and wipe it to remove any oil.

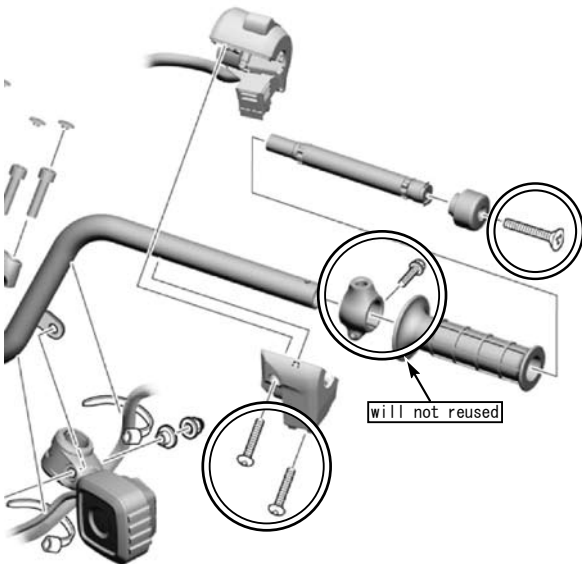

○ After the mirror holder is removed, attach the handle switch ASSY. on the Left side. Apply a little Honda genuine adhesive A or Cemedine F540 to the grip rubber, and while the adhesive surface is still dry, rotate the grip and attach the steering handle weight.

▲ Note: Be sure that you protect specified torque.
L switch ASSY., Bolt
Torque : 2.5N · m (0.25kgf · m)
Steering weight, Bolt
Torque : 9.0N · m (0.9kgf · m)

○ As shown the photo, install the clutch master cylinder and set as the UP Δ mark on the holder on the top side. Pre-tighten the flange bolts M6x22, adjust the lever position, and full tighten them to the specified torque starting from the top.

※ Remove the switch of the clutch master cylinder(it will not re-use).

▲ Note: Be sure that you protect specified torque.
Torque : 12N · m (1.2kgf · m)



□ Preparation for clutch disassembly

○ Remove the trim clip that secures the main pipe lower cover.

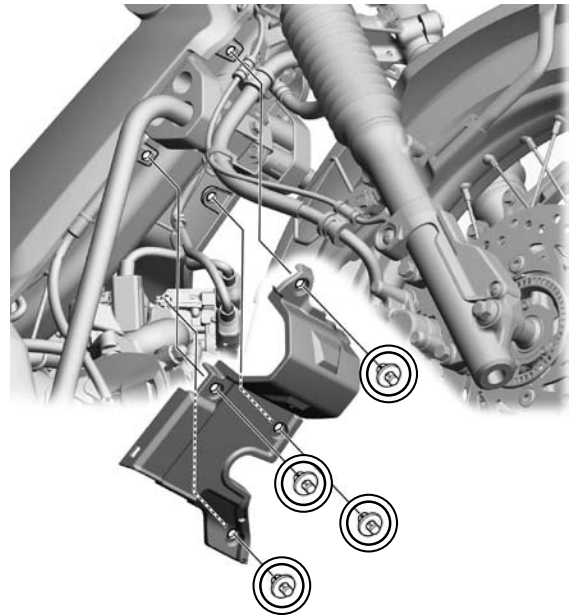

○ Remove the four 6x10 screws of the under guard.

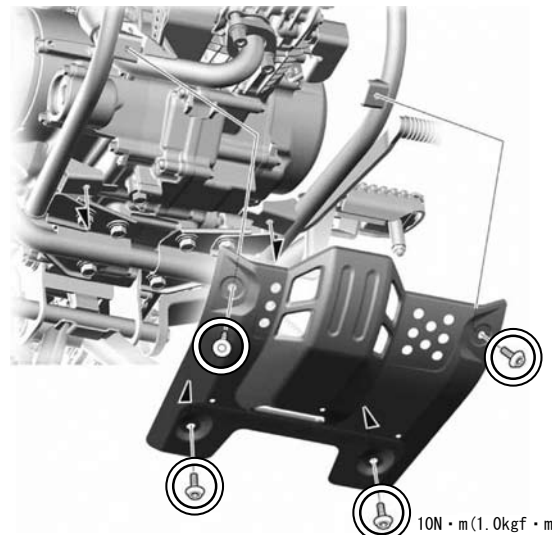

○ Remove the two flange bolts 8x16 and four socket bolts 8x16 and 6x12 bolt washers, and carefully remove the under guard pipe.

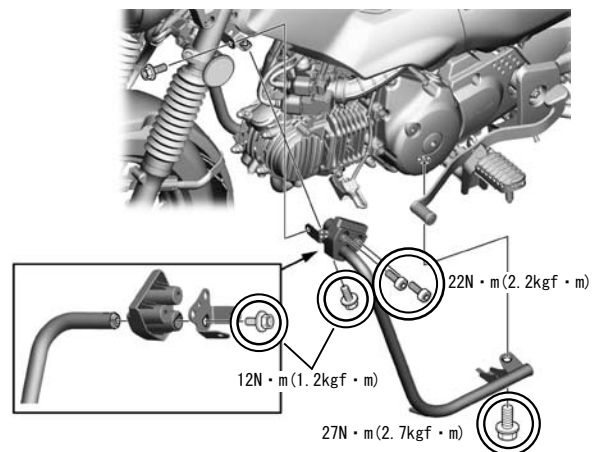

□ Preparation for clutch disassembly

○ Remove the 6x14 pan screws and trim clips and remove center cover. (note:care about the clips)

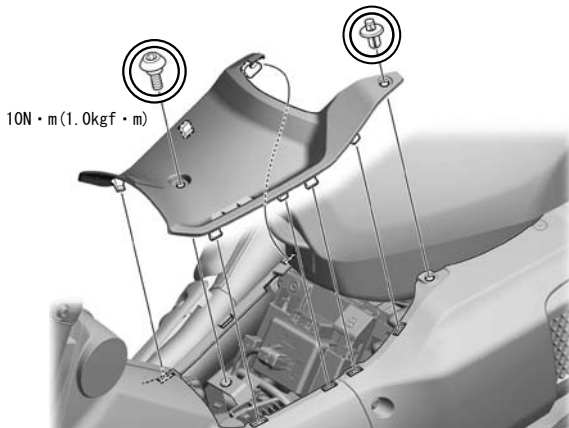

○ Remove the 5x14 pan screw and trim clip and remove air cleaner garnish. (note:care about clips)

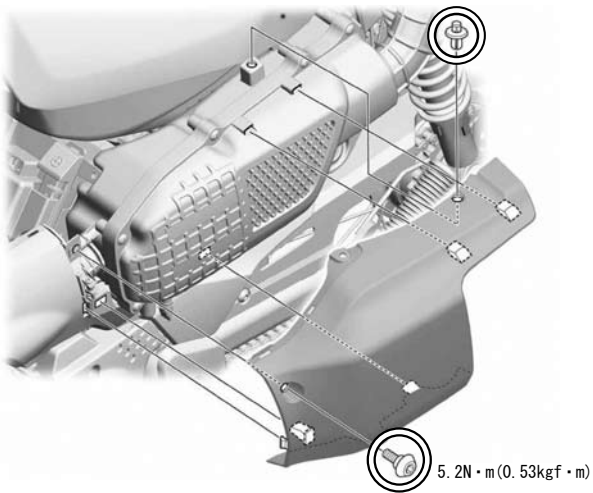

○ Remove the M10 flange nut and M8x16 flange bolt that secures the left pivot plate. Remove the M6x20 flange bolt and remove gear shift pedal.

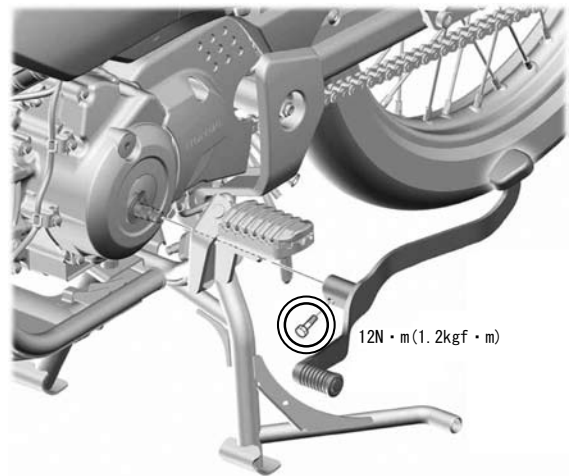
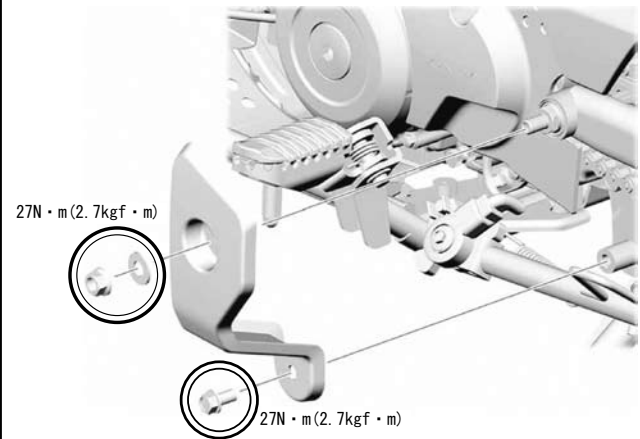

□ Preparation for clutch disassembly

- To remove the stand switch connector, remove the two flange bolts 6x25 and clips of the wiring and remove sprocket cover. Remove the 2P connector inside the boot.

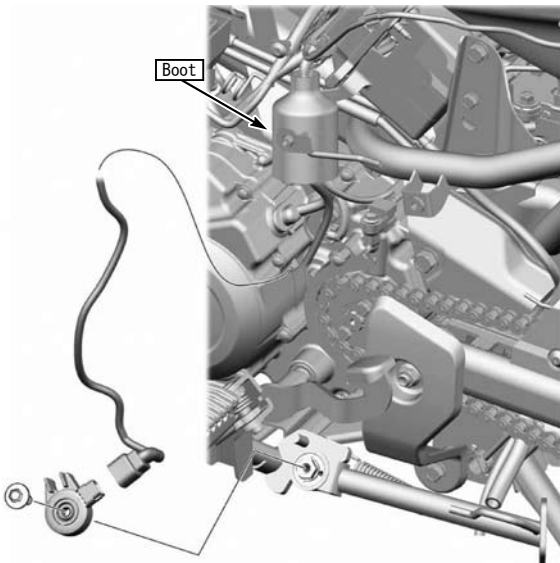
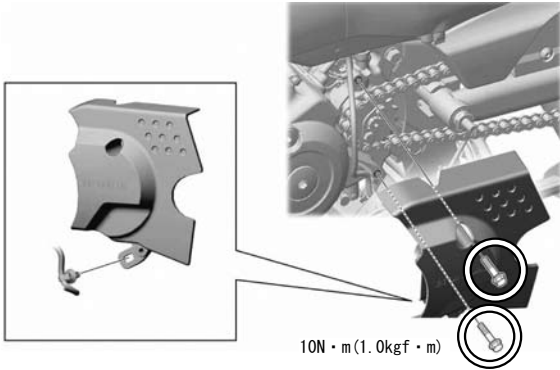

- Remove the four M8x20 flange bolts and 8.5x20 washers and remove the step.

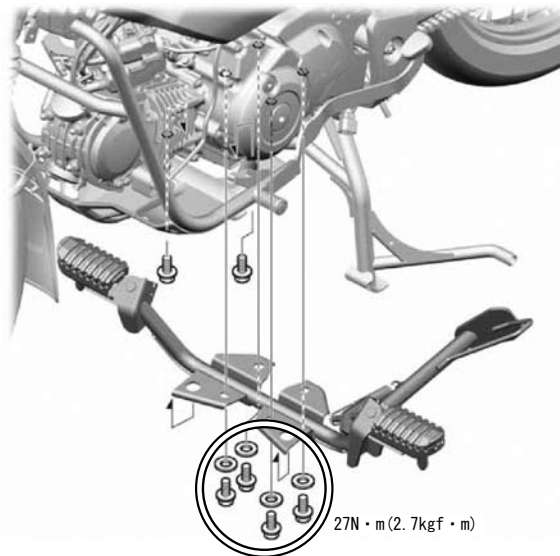

- Remove the 6x25 flange bolts and kick starter arm from the shaft.

- Remove the 12mm flange U nut that secure the R. pivot cover, the M8x16 flange bolt, and the return spring of the brake switch. Make little space and protect swing arm by rug, move the R. step holder backwards, and keep little enough space to remove the clutch cover.

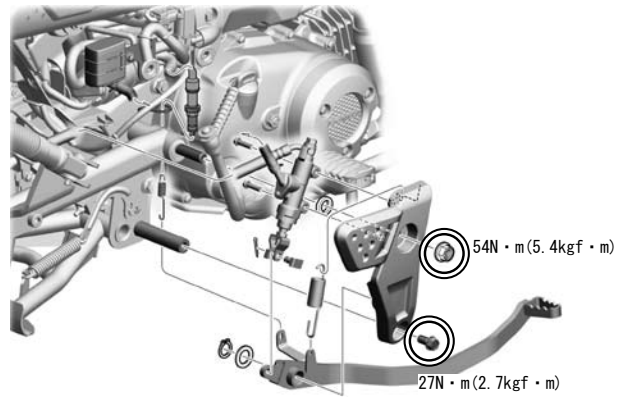

- Prepare the oil pan and remove the drain bolt to drain the oil.

□ R. crankcase cover/clutch removal (of unnecessary inner parts)

- Remove the clutch adjuster nut (8mm washer, and O-ring).
- ※ Washer 8mm will be reused.

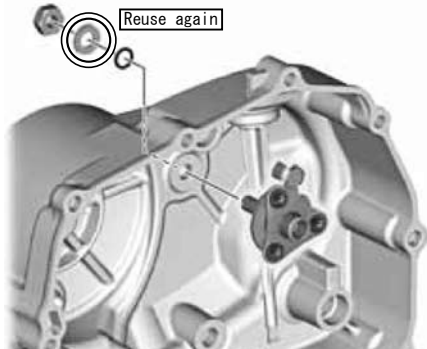

- Remove the flange bolts 6x35 (10 pieces) and two clamps at right side crankcase cover. Gently remove the R. crankcase cover (not drop dowel pin and oil jet).
- ※ Check the condition of the dowel pin and replace them if necessary.

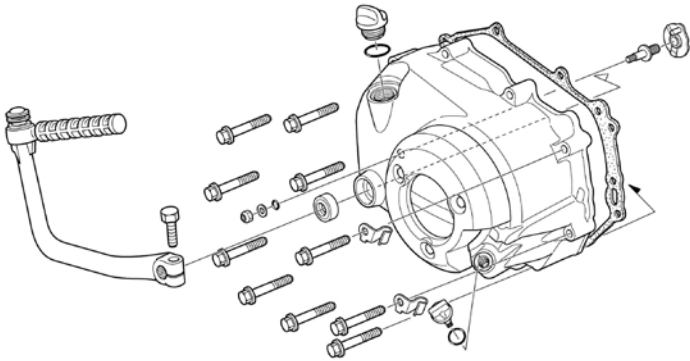

- Remove the following parts.
- ※ All of the following parts will not be reused.
- Clutch lever COMP. / Brake plate COMP.
- Ball retainer COMP. / Cam plate side spring
- Clutch adjusting bolt / Clutch lifter plate COMP.
- Clutch cam plate COMP.

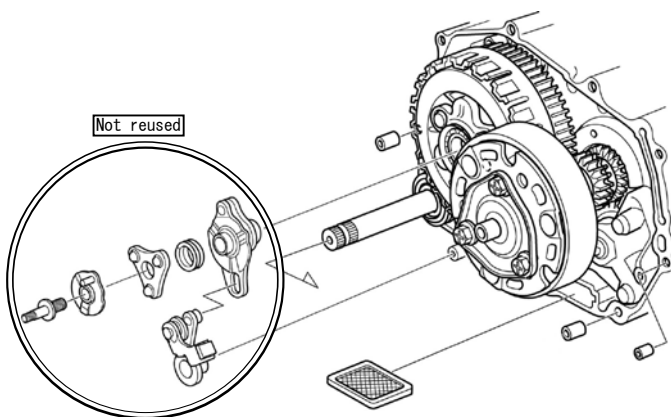

□ Assemble Clutch release cylinder

- As shown diagram, slim line banjo and banjo bolt (SUS/M8/L:38) with a 10mm aluminum sealing washer.
- Set the O-ring 8mm and the stock washer 8mm on the R. crankcase cover in this order.
- Apply a little multi-grease to a 12.5mm O-ring and attach it to the groove of the clutch release cylinder. Align the notch of the clutch release cylinder with the rib of the crankcase cover, then insert the set banjo bolts into the clutch release cylinder. Attach to the threaded part to adjust the angle of the slimline banjo. Screw lightly in the O-ring 12.5mm (to not fall off).

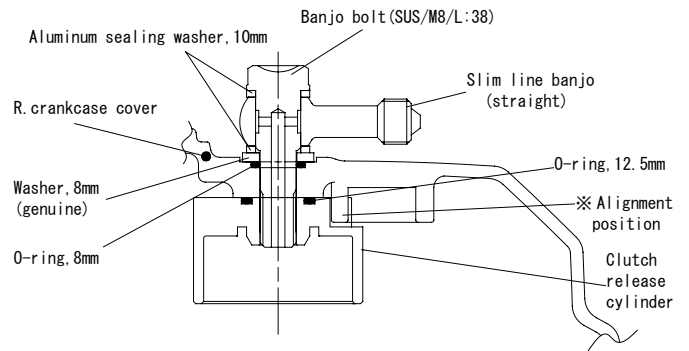

□ Assemble around the release piston

- Apply a little rubber grease to the O-ring 30mm (SBR/NBR), let it soak in, and then attach it to the release piston.
- ※ Each O-ring has its own mounting position.
- As shown diagram, install the both O-ring (SBR) on the brake fluid side and the O-ring (NBR) on the clutch side.
- Apply little rubber grease to the inside of the clutch release cylinder as a diagram.
- Set the clutch release spring in the groove of the release piston, and install inside the cylinder. (note: pay attention to the O-ring)
- ※ Do not install the piston in an inclined or wrong position. The O-ring may break.
- Apply a small amount of engine oil to the clutch lifter-rod and assemble it onto the clutch lifter bearing, as a diagram.

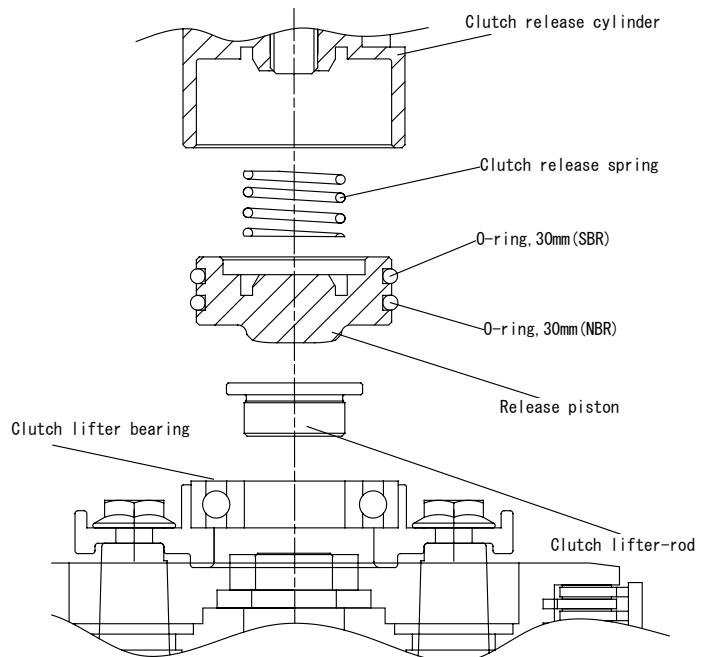

■ Mounting procedure ※ Please refer to the Genuine Service Manual for detailed mounting methods and specified torques that are not specifically described.

□ Assemble R. crankcase cover

- Attach the stainless steel shim ring (Φ 10.2x Φ 22x1.5) to the gear shift spindle as shown in the photo.



- After removing the oil screen filter and cleaning it thoroughly, assemble the tapered side of the oil screen filter to the crankcase.

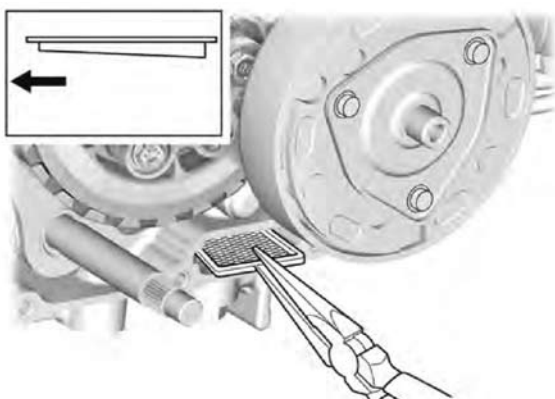

- After cleaning and degreasing the surfaces of the R. crankcase cover, install the two dowel pins 8x12, OIL jet and R. crankcase cover gasket.
- R. Attach the crankcase cover and tighten 6x40 flange bolts diagonally several times with specified torque, using flange bolts 6x40 (10 pcs) and clamps (2 pcs).

▲ Note: Be sure that you protect specified torque.
Flange bolt
Torque : 12N · m (1.2kgf · m)

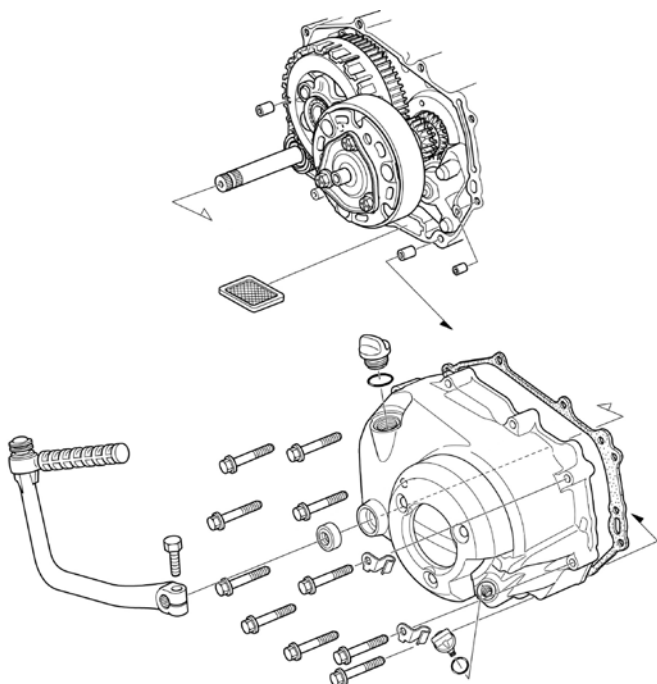

□ Oil line(slim line) connection

- As shown photo, sandwich the slimline banjo (straight) with a 10mm aluminum sealing washer, banjo bolt(w/air-breeder), tighten it to the specified torque.
- Install the air-bleeder screw with the rubber cap on the banjo bolt.

▲ Note: Be sure that you protect specified torque.
Banjo bolt (w/air-breeder)
Torque : 15N · m (1.5kgf · m)
Bleeder screw
Torque : 5.0N · m (0.5kgf · m)



- As shown photo, pre-fix the brake hose fitting to the slim line banjo (straight) and route the hose note: not interfere any part of the exhaust pipe and steering wheel operation. Attach using cable ties 150mm and cushions (15x140x5) if necessary. Once the routing is fixed, adjust the angle of the slimline banjo that pre-attached on the clutch side and tighten the banjo bolt (SUS/M8/L:38) to the specified torque.

▲ Note: Be sure that you protect specified torque.
Banjo bolt (SUS/M8/L:38)
Torque : 18N · m (1.8kgf · m)
Brake hose (fitting)
Torque : 6.0N · m (0.6kgf · m)



■ Mounting procedure ※ Please refer to the Genuine Service Manual for detailed mounting methods and specified torques that are not specifically described.

□ Discharge air (air-bleeding)

- Remove the bleeder cap of the clutch master cylinder, check that the bleeder screw and banjo bolt are tightened, fill the brake fluid to the upper level of the reservoir, and operate the clutch lever to fill the clutch system with brake fluid.
Continue this operation until no bubbles come out from the primary port in the reservoir (until you feel a weight on the clutch lever).
- ※ Do not mix different brands fluids (to prevent chemical effect).
- ※ Brake fluid can damage painted surfaces (avoid getting it on parts). If it gets, wash it with water.



- Attach the clear tube to the bleeder screw and lead it with a bottle. Hold the clutch lever until the lever tip touches the handle grip, loosen the bleeder screw about 1/2 turn, tighten it again, and slowly release the clutch lever. Once lever has returned completely, leave it there for a few seconds.
- ※ Do not return the lever while the bleeder screw loosened.
- Repeat this until no air bubbles come out of the clear tube.
- ※ Keep attention to the brake fluid level in the master cylinder cup, refill when it to near the lower level.
- Tighten the bleeder screw to the specified torque.

▲ Note: Be sure that you protect specified torque.
Bleeder screw
Torque : 5.0N · m (0.5kgf · m)

- After air bleeding is complete, fill the brake fluid to the upper limit line of the reservoir and install the diaphragm and reservoir cap.

▲ Note : If the air bleed is not well, the clutch may not dis-engage smoothly, difficult to shift gears smoothly, and if the engine gets hot, the clutch may unable to dis-engage.

□ Re-assemble

- Put back to parts as reverse order.

□ Clutch operation check

※ Perform with engine stopped.

- Without engine start, shift the transmission to 1st gear and squeeze the clutch lever. Check that the rear wheel rotates when the motorcycle push to forward and does not rotate when the clutch lever is released.
- ※ If the rear wheel does not rotate even hold the clutch lever in 1st gear, do bleed the air again.
- ※ Engine is not started, gear is in(not neutral) and even clutch lever is not operate, wheel still can move backwards. This is OK (it is a characteristic of a one-way centrifugal clutch).

□ Pour the engine oil

- Replace the new sealing washer and tighten the drain bolt to the specified torque.

▲ Note: Be sure that you protect specified torque.
Drain bolt
Torque : 24N · m (2.4kgf · m)

- Pour the engine oil.

At draining : 0.8 ℓ
At oil filter replacing : 0.85 ℓ
Full capacity : 1.0 ℓ

- Confirm that there are no oil leaks from any part, stop the engine, and after about 1 minute check if the oil level gauge is within the standard range. When it's low, add it.
- Start the engine with the transmission in neutral and perform a low-speed driving test in a safe road to check clutch operation.

■ Troubleshooting

Symptoms	Answer (Solution)
• The engine starts normally but stops when I shift to 1st gear.	<ul style="list-style-type: none"> ➔ Please check if the stand switch connector, connection is OK. ➔ Check that the stand switch wiring is not disconnected.
• At the release piston, there are two types of 30mm O-rings attached, SBR and NBR, but I can't tell which is, what will happen if I don't use it in the specified location?	<ul style="list-style-type: none"> ➔ Each O-ring has its own purpose. NBR is sealing engine oil. SBR is sealing brake fluid. ➔ If you attach it in the wrong place instead of in the designated place, the O-ring will be corroded and will no longer be able to fulfill its role as a seal, leading to fluid leakage. ➔ O-rings are looks same. The SBR O-ring is stamped SBR on the packaging bag.
• I can't dis-engage the clutch. Heavy touch when shifting to 2nd or 3rd gear, and have to squeeze the lever at full positions to the clutch can dis-engage.	<ul style="list-style-type: none"> ➔ If there is no wrong assembly, there is a high possibility that the air has not been completely discharge. Air may move upwards by tilting the vehicle, or gently tapping the brake hose by hand to give it vibration.
• When the engine is cold, the shifting can be performed normally, but as the engine gets hot, the shifting becomes harder.	<ul style="list-style-type: none"> ➔ There is a high possibility that the air has not discharged properly. As the engine temperature increases while running, if air is remain in the clutch oil line or release piston, the air will expands, cause to failure of the clutch. We recommend that you bleed the air again.
• Brake fluid leaks from the banjo bolt (SUS).	<ul style="list-style-type: none"> ➔ Are you using a new aluminum sealing washer? If you use an old and crushed, the washer seal may not work properly. ➔ Are the aluminum sealing washers or hose fittings you are using made by our company? If you are using other brand's banjo bolt, may not be fully tightened if the thickness is different. Please use our kit parts.
• The shift pedal has an unusually light compared to the stock. Is this normal?	<ul style="list-style-type: none"> ➔ It's normal. Clutch operation is done with a light touch because the lever does not push the lifter plate.
• The engine is started, shift to 1st gear, and release the clutch lever, the vhecle does not move and engine not stop. Is something wrong? • At the rear wheel raised on the center stand (or racing stand) why rear wheel not rotate even if I start the engine, shift to 1st gear, and release the lever.	<ul style="list-style-type: none"> ➔ It's normal. The clutch (on the crack side) is centrifugal, and as the engine speed increases, power is transmitted to the rear tires. When the revs higher, power transmission can be operated by clutch lever at hand. This product still has an automatic centrifugal clutch near idling speed. So the bike won't move forward and the engine won't stop.
• When the engine is stopped and the transmission is in any gear, I cannot move forward without holding the clutch lever, but I can move backward. Is this normal?	<ul style="list-style-type: none"> ➔ It's normal. If you roll the vehicle backwards without releasing the clutch lever with the engine stopped and even not neutral, it will move. The centrifugal clutch on the crank side is a one-way clutch, so it is not trouble or problem.