



INSTALLATION INSTRUCTIONS

Accessory
CB ANTENNA
P/N 08E70-MKC-L00

Application
GL1800/D/DA

Publication No.
MII 17686
Issue Date
February 2021

Honda Dealer: Please give a copy of these instructions to your customer.

PARTS LIST

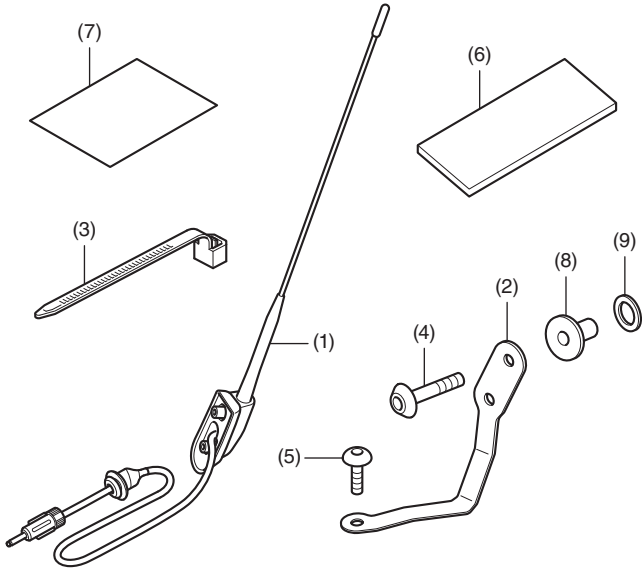

No.	Description	Qty
(1)	CB antenna	1
(2)	CB antenna stay	1
(3)	Wire tie (short)	2
(4)	6 mm bolt (long)	2
(5)	6 mm bolt (short)	1
(6)	Cushion	1
(7)	Installation Instructions URL	1
(8)	Collar	2
(9)	Rubber	2

CB RADIO & ATTACHMENT

Sold separately

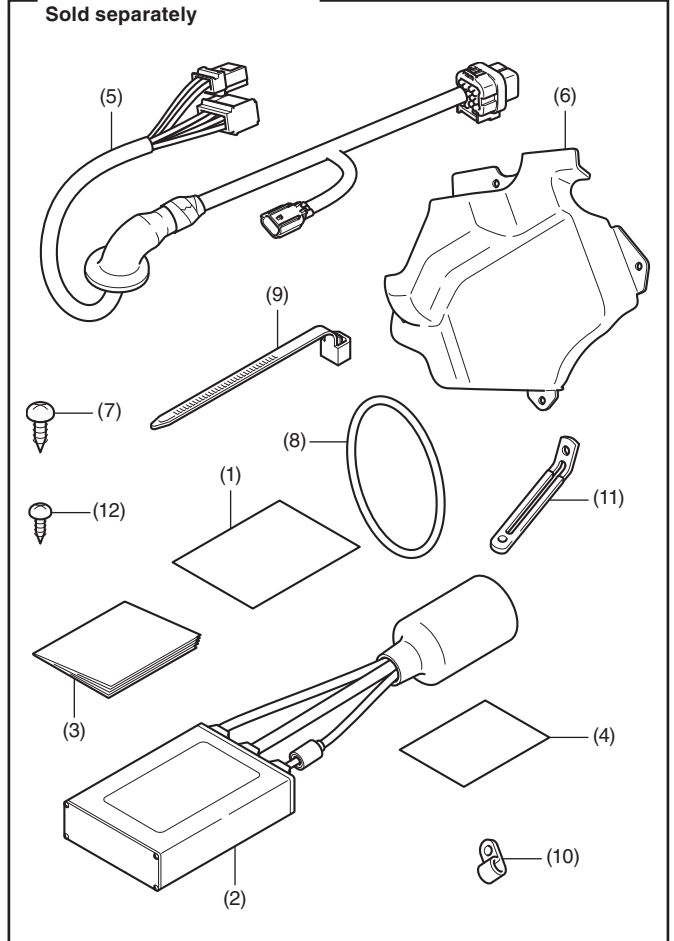

No.	Description	Qty
(1)	Installation Instructions URL	1
(2)	CB main unit	1
(3)	CB radio owner's manual	1
(4)	FCC rule book	1
(5)	CB radio sub harness	1
(6)	CB unit cover	1
(7)	5 mm screw	7
(8)	O-ring	1
(9)	Wire tie (long)	2
(10)	Clip	2
(11)	Clamp	1
(12)	4 mm screw	1

TOOLS AND SUPPLIES REQUIRED

Hex wrench (5 mm)
Phillips screwdriver
Dish soap solution
(Water : Dish soap / 100 : 1)
Snips
Electric drill
Drill bit (14 mm)
Hole saw (16 mm)
Marker
Scale
Scissors
Isopropyl alcohol
Shop towel
Torque wrench

TORQUE CHART

Tighten all screws, bolts, and nuts to their specified torque values. Refer to the Service Manual for the torque values of the removed parts.

Item	N·m	kgf·m	lbf·ft
4 mm screw	1	0.1	0.7
5 mm screw	4.2	0.4	3.1
6 mm bolt	9	0.9	6.6

INSTALLATION

▲ CAUTION

- To prevent burns, allow the engine, exhaust system, radiator, etc., to cool before installing the accessory.

NOTE:

- Heat the bonding surfaces with a hair dryer if the ambient air temperature is below 70°F (21°C).
- The adhesive reaches full strength in 72 hours. Wait at least 24 hours before riding your motorcycle.
- Disconnect the negative (-) cable from the battery before installing this accessory.
- The clock memory will be erased when you disconnect the battery. Reset the clock after reconnecting the battery.
- Reinstall the removed parts on the motorcycle and make sure that the wires and harnesses are not pinched.
- Trim the excess ends off the wire ties after attaching them to the wire harnesses. Do not allow the cut part of the wire tie to interfere with another harness or brake hose.
- For installation of CB switch and CB passenger switch, refer to the installation instructions for the each accessory.

1. Open the left saddlebag lid as shown.
 - Repeat on the right side.

<Left side>

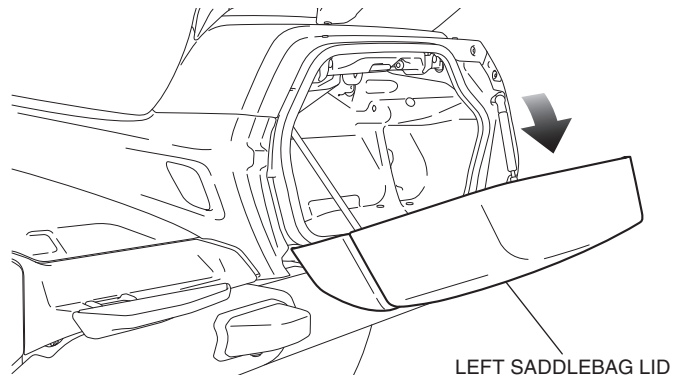

2. Remove the left side cover as shown, and disconnect the negative (-) cable of the battery.

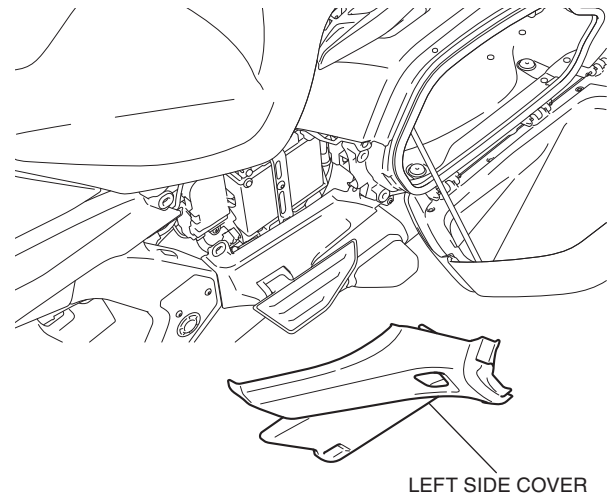

3. Remove the right side cover in the same manner as the left side.
4. Remove the seat as shown.

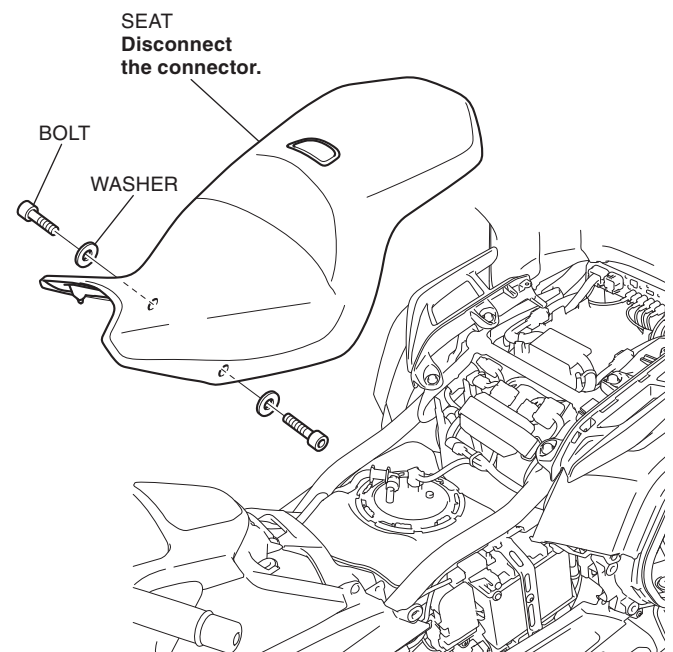

5. Remove the right passenger grip as shown.

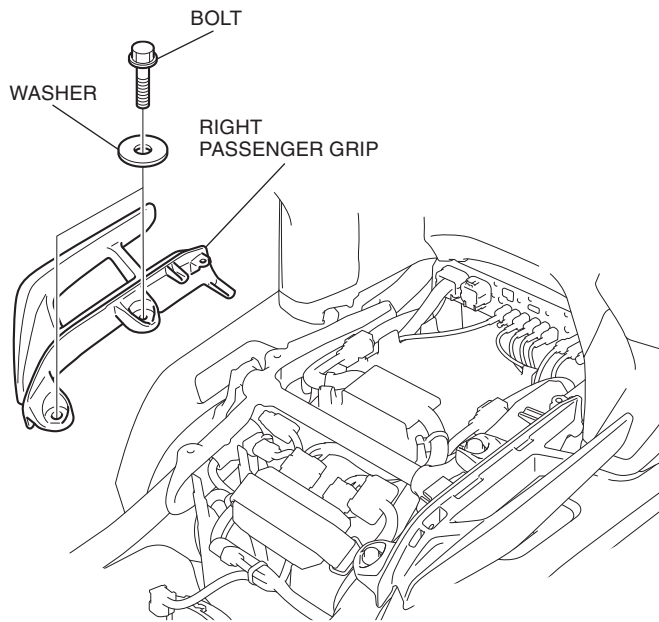

6. Open the rear trunk lid as shown.

- Refer to the Owner's Manual for instructions on how to use the emergency trunk cable to open the rear trunk lid.

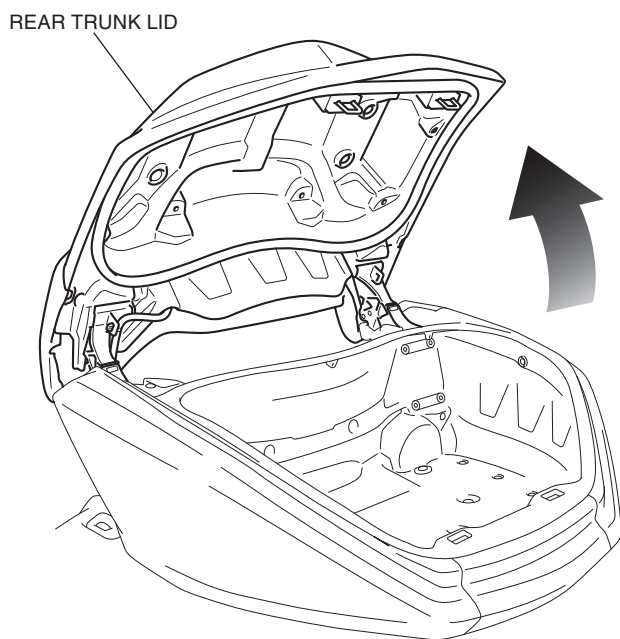

7. Remove the USB code as shown.
• Perform this step on GL1800DA only.

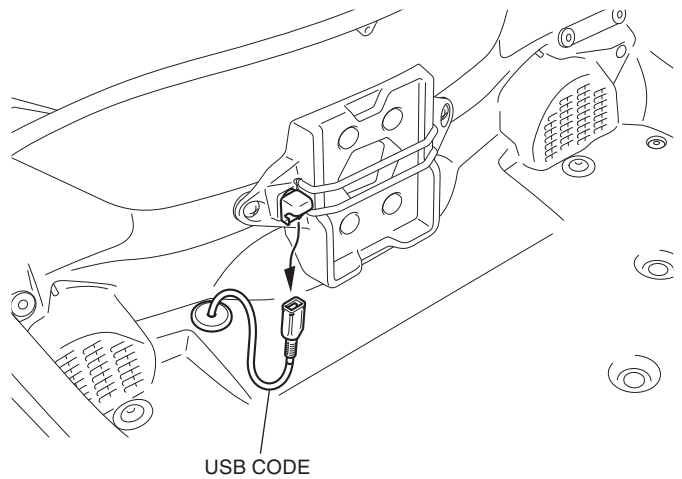

8. Remove the parts as shown.

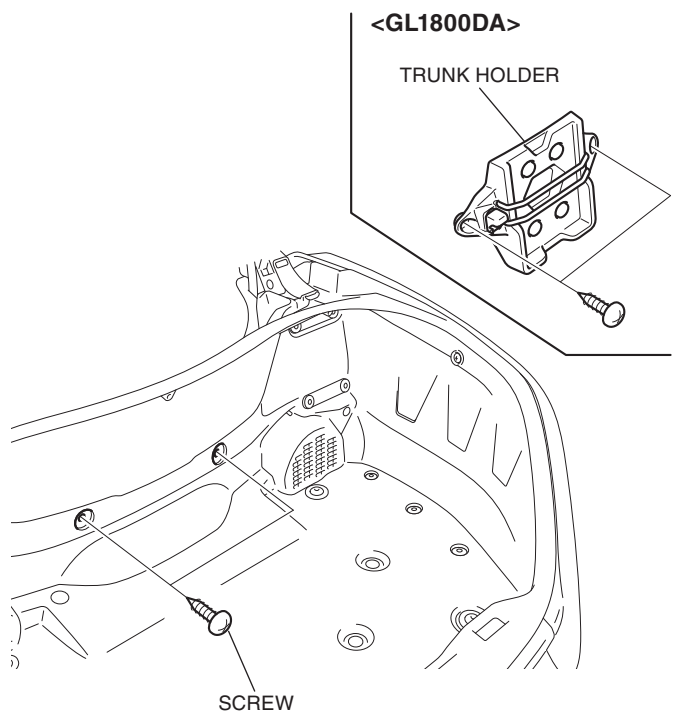

9. Remove the front trunk lower panel as shown.

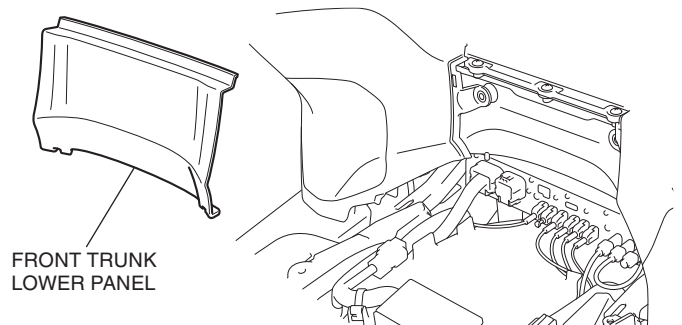

10. Remove the parts as shown.

- Repeat on the left side.

<Right side>

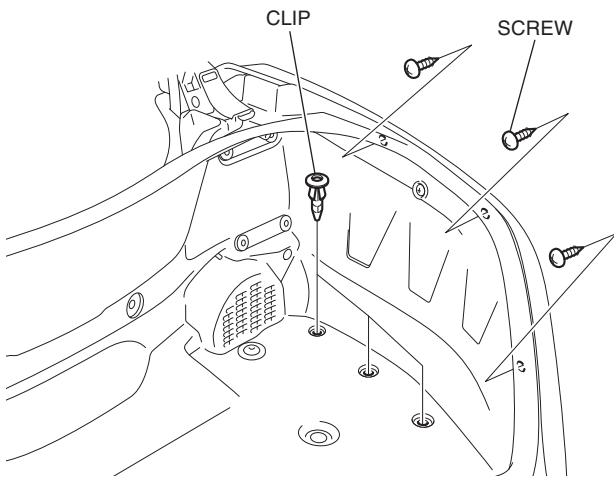

11. Remove the parts as shown.

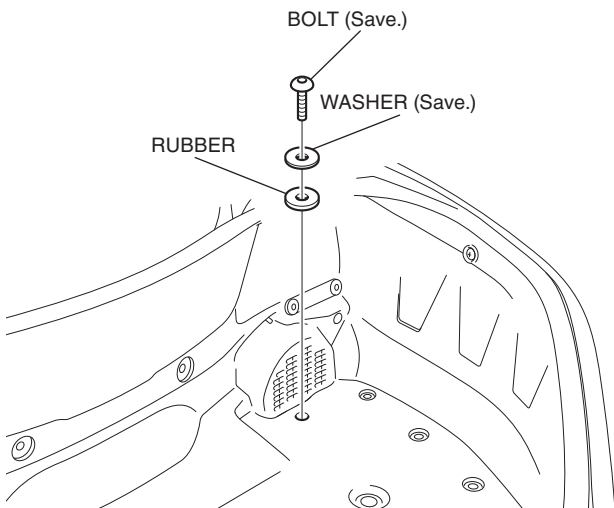

12. Remove the right trunk side cover as shown.

- Repeat on the left side.

<Right side>

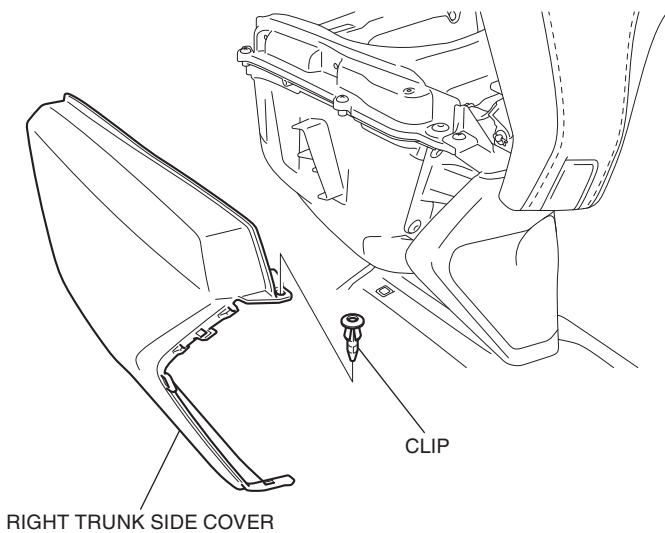

13. Remove the right trunk front cover as shown.

<Right side>

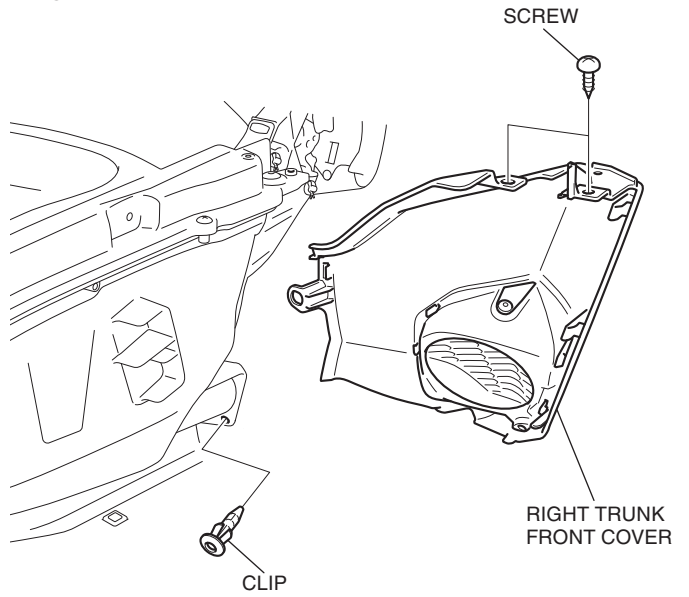

14. Disconnect the connector and remove the center trunk lower cover as shown.

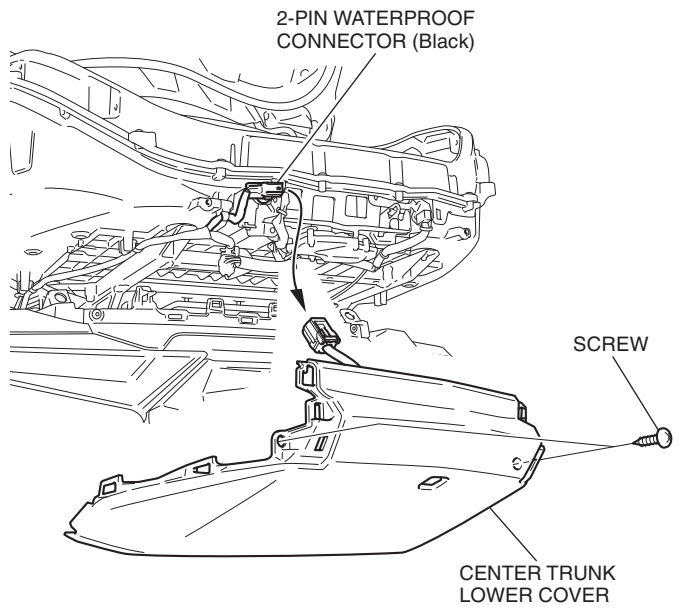

15. Remove the clip as shown.

<Right side>

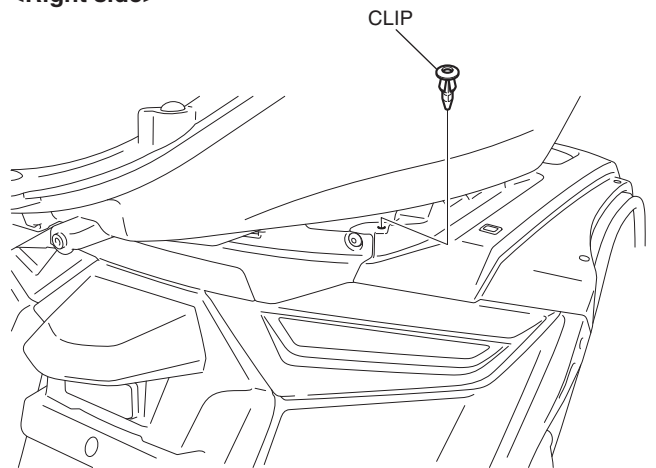

16. Remove the rear fender as shown.

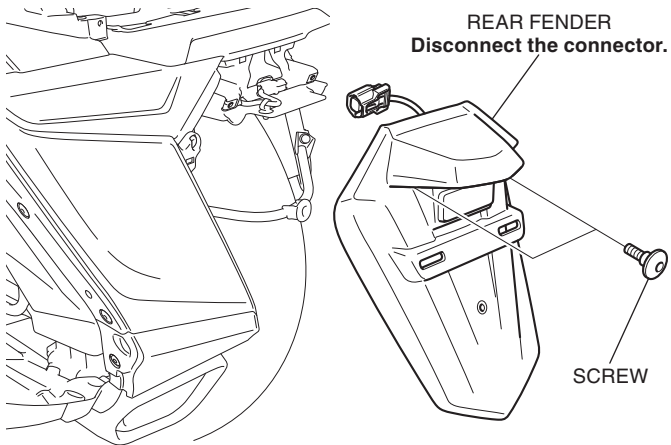

17. Remove the saddlebag rear center cowl as shown.

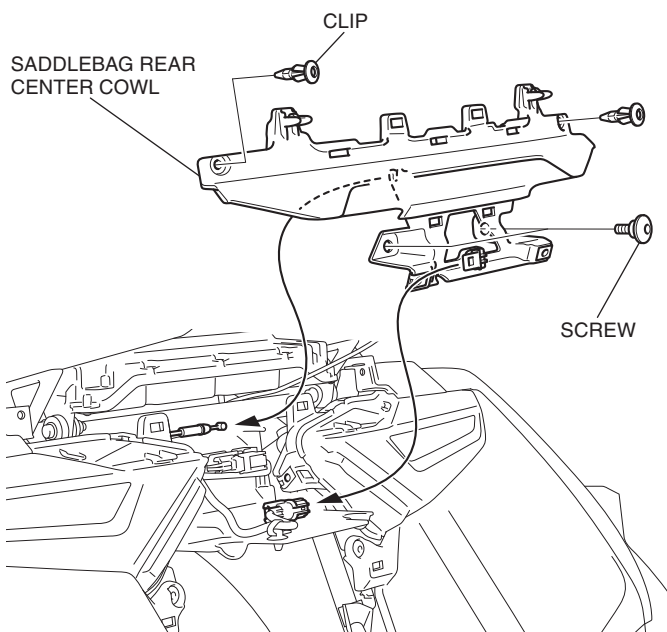

18. Remove the right saddlebag upper cover as shown.
<Right side>

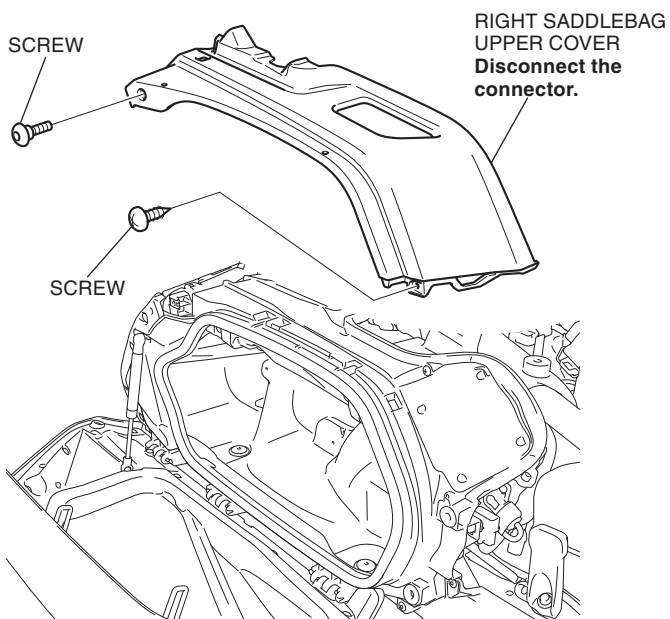

19. Remove the grommets as shown.

<Right side>

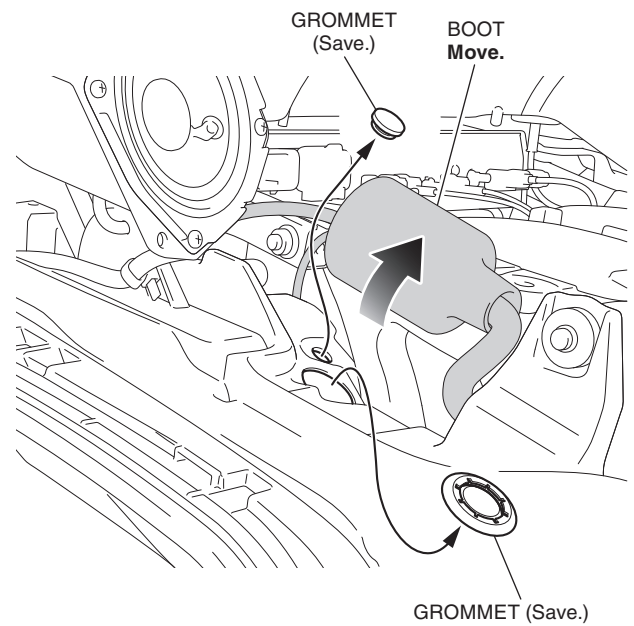

20. Clean the surface of the area shown using isopropyl alcohol.

<Right saddlebag>

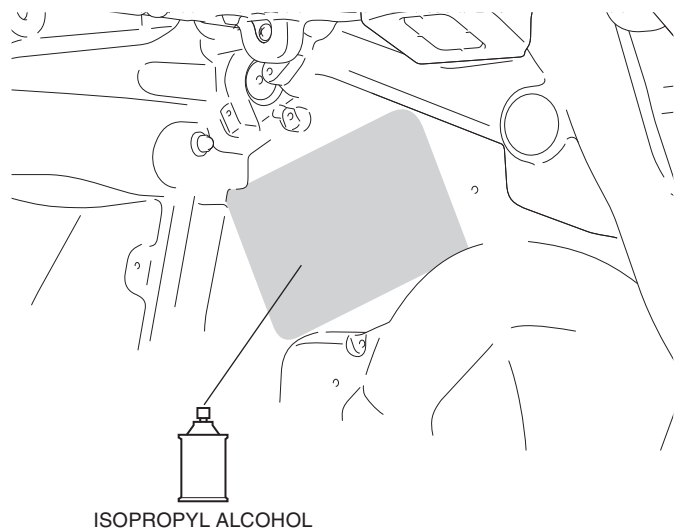

21. Attach the CB main unit as shown.

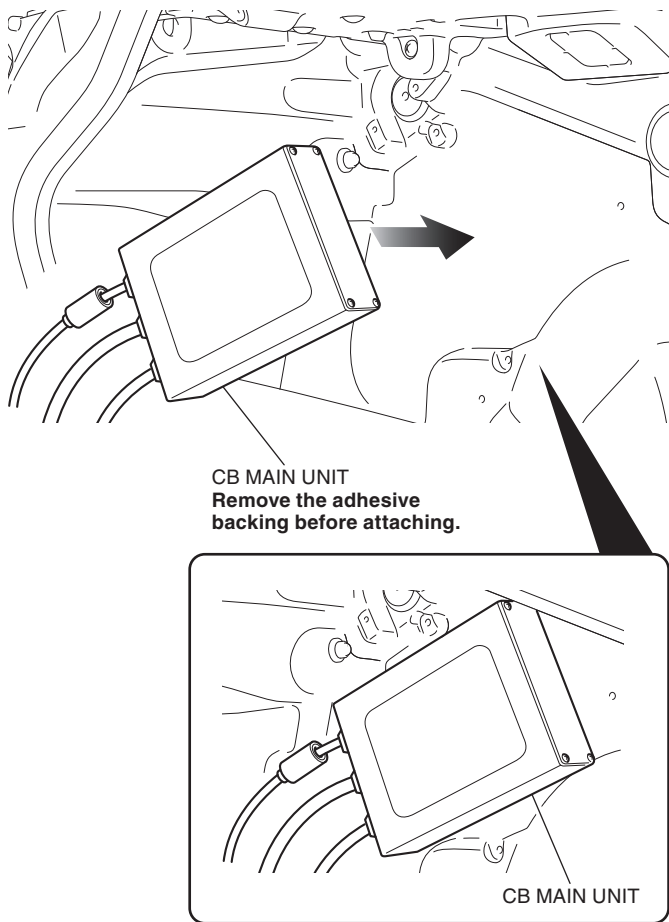

22. Install the clips to the O-ring as shown.

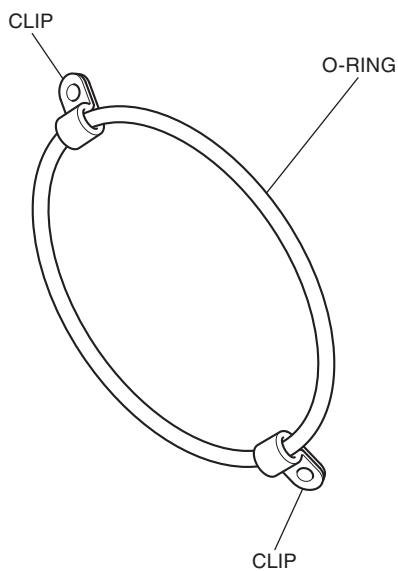

23. Install the clips as shown.

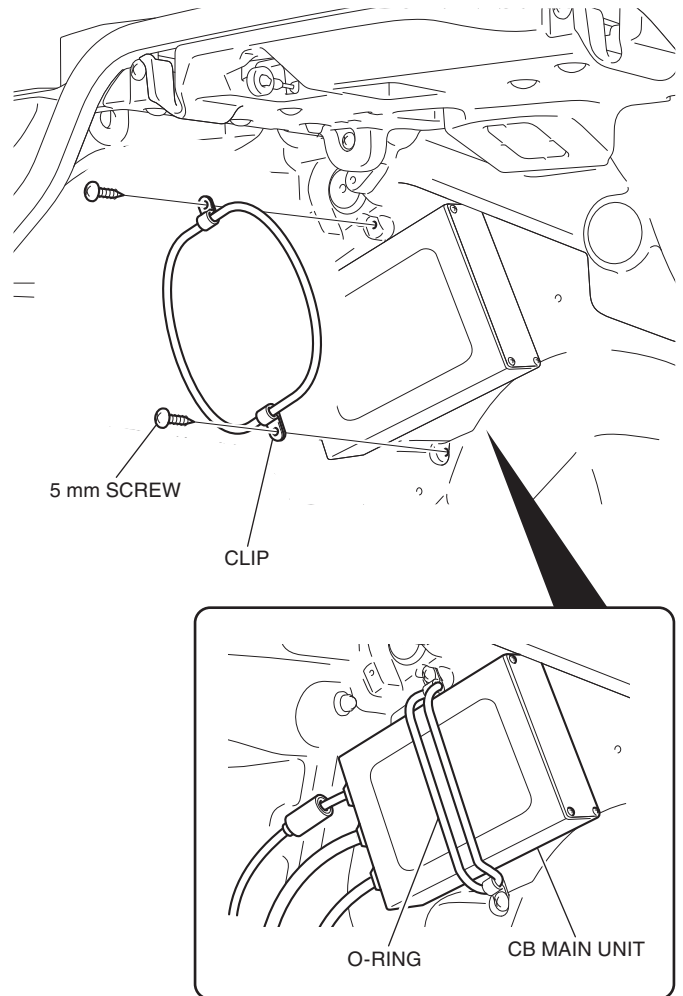

24. Install the clamp as shown.

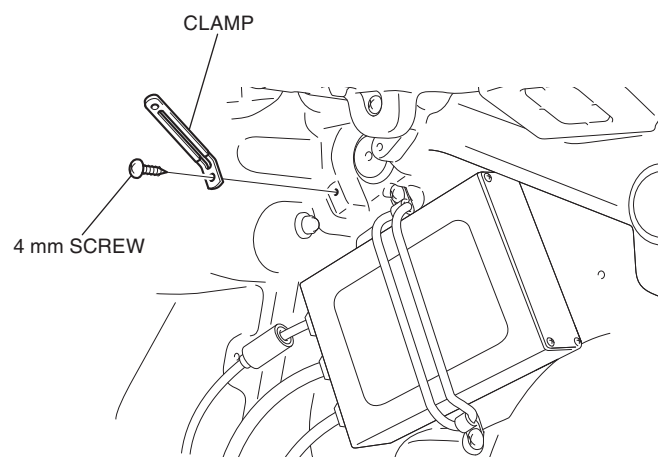

25. Remove the screws as shown.

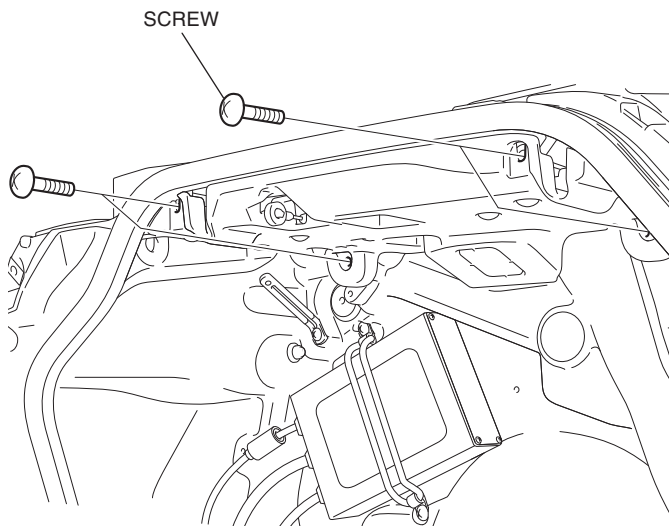

26. Remove the connector as shown.
<Right side>

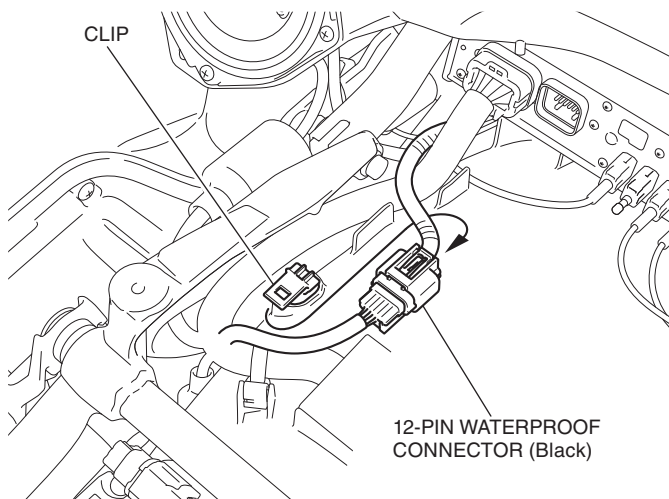

27. Route the CB radio sub harness as shown.

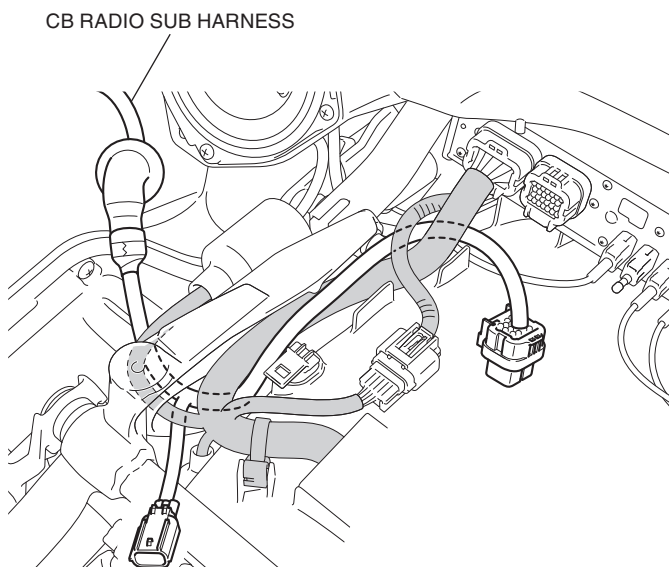

28. Apply dish soap solution to the position shown.

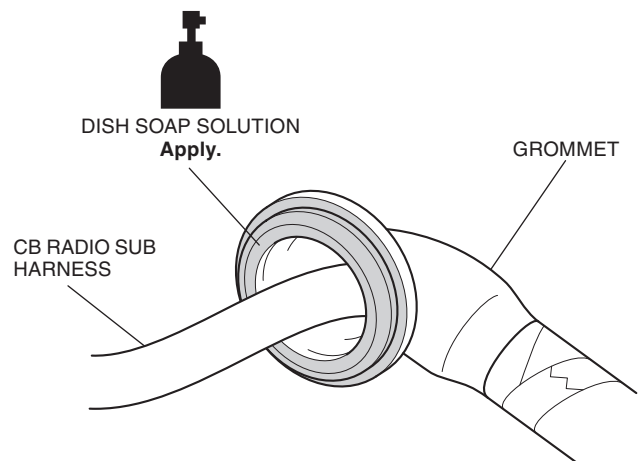

29. Route the CB radio sub harness as shown.
<Right side>

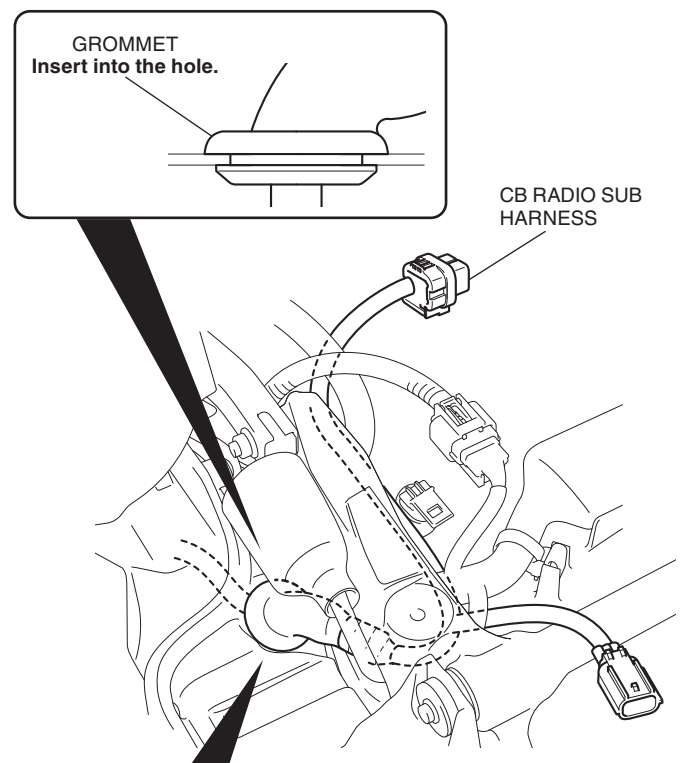

Move the right saddlebag catch and route the CB radio sub harness as shown.

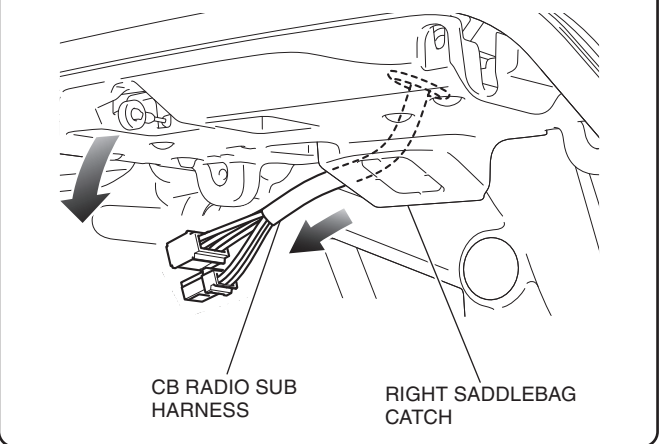

30. Connect the CB radio sub harness as shown.

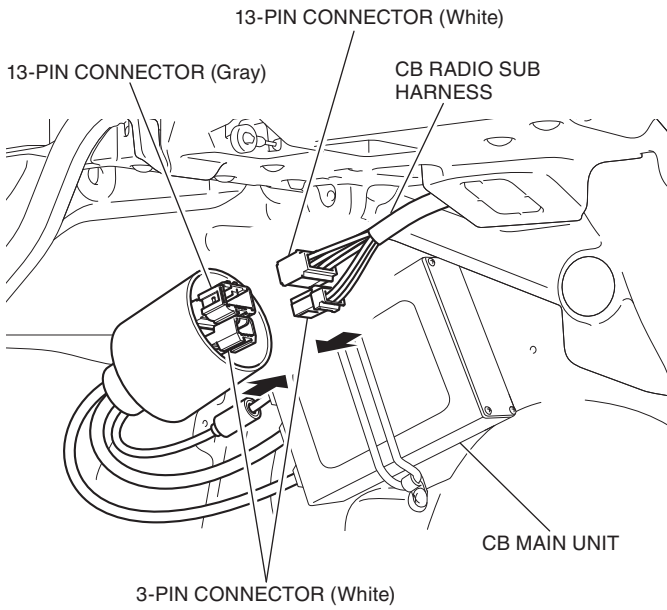

31. Install the right saddlebag upper cover, saddlebag rear center cowl, rear fender and center trunk lower cover in the reverse order of removal.

32. Drill at the marked points of the trunk inner box as shown.

- Remove any burrs from the edge of the hole.

<Right side>

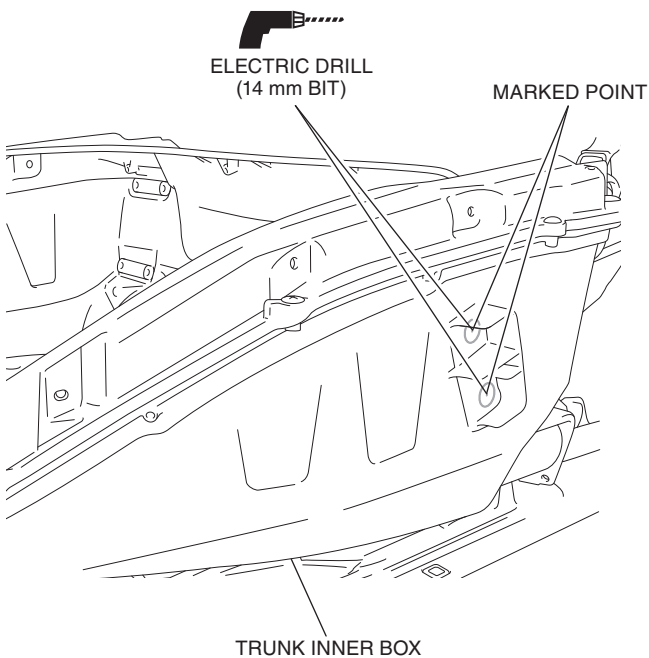

33. Drill at the marked points of the right trunk side cover as shown.

- Remove any burrs from the edge of the hole.

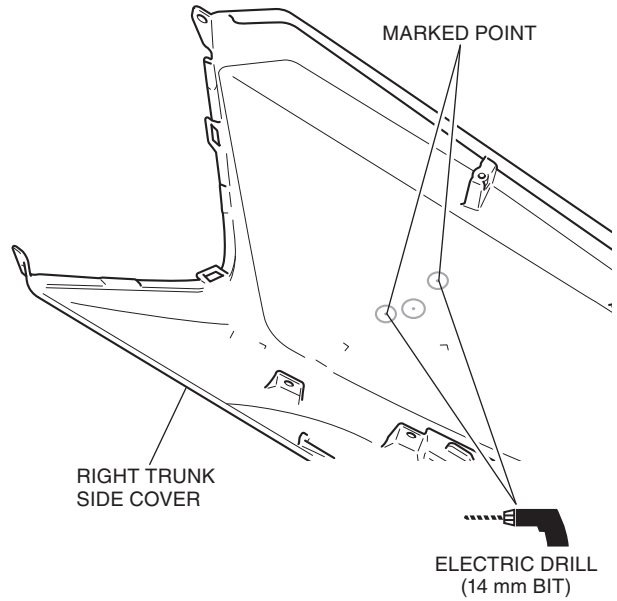

34. Drill at the marked point of the right trunk side cover as shown.

- Remove any burrs from the edge of the hole.

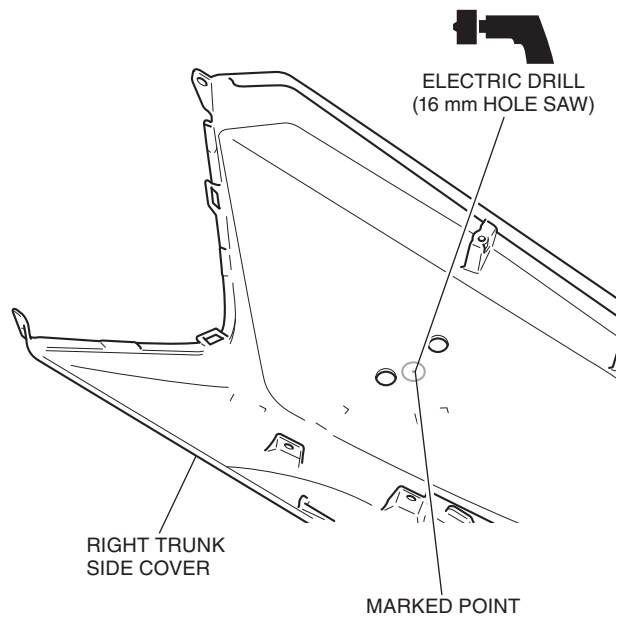

35. Clean the surface of the area shown using isopropyl alcohol.

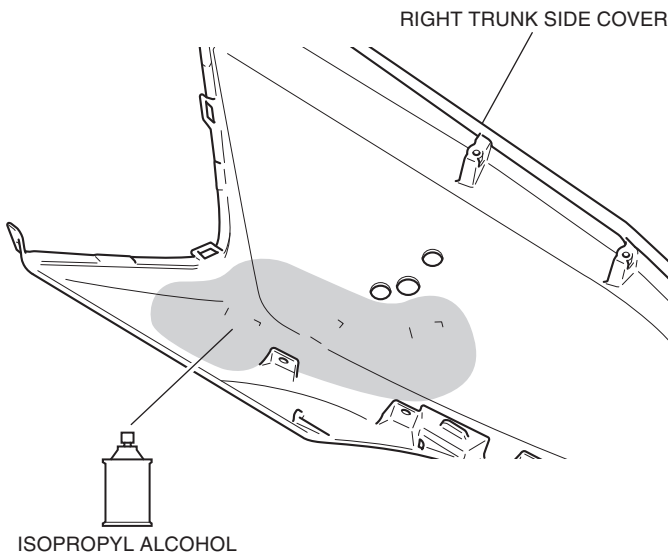

36. Mark the CB antenna code in the position shown.

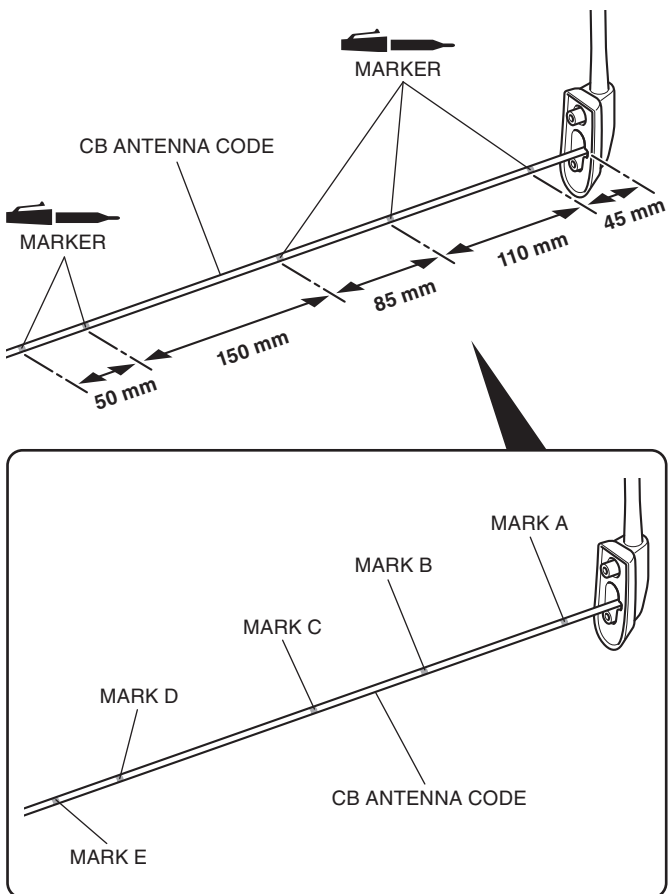

37. Route the CB antenna code as shown.

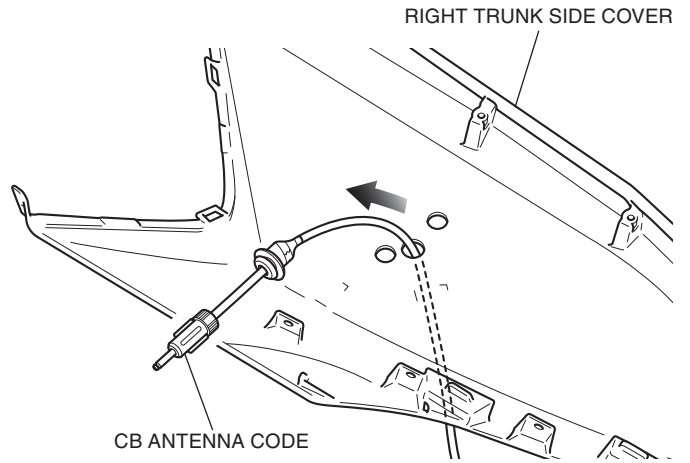

38. Cut the cushion to the dimensions shown.

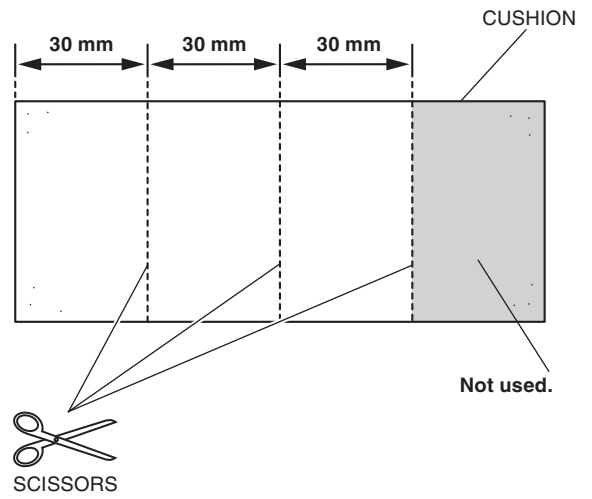

39. Attach the cut cushions as shown.

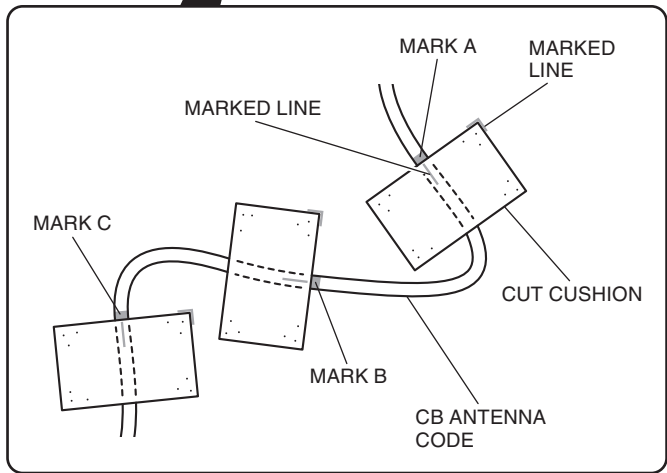
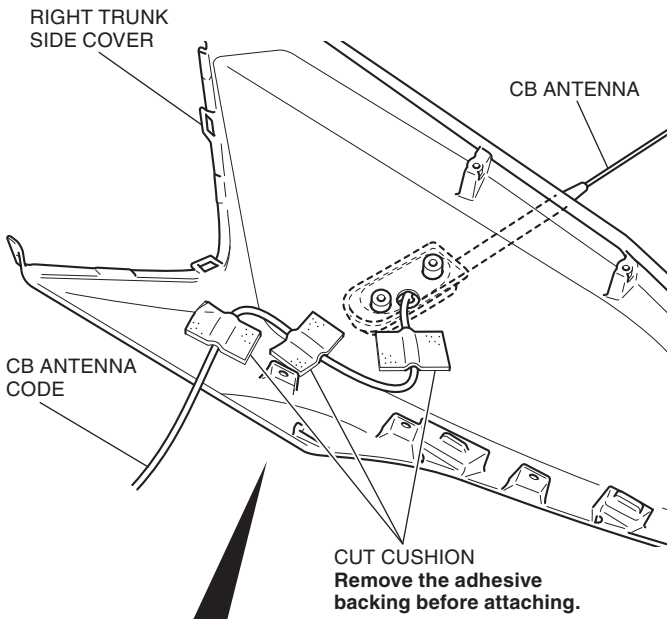

40. Loosely install the wire tie as shown.

<Right side>

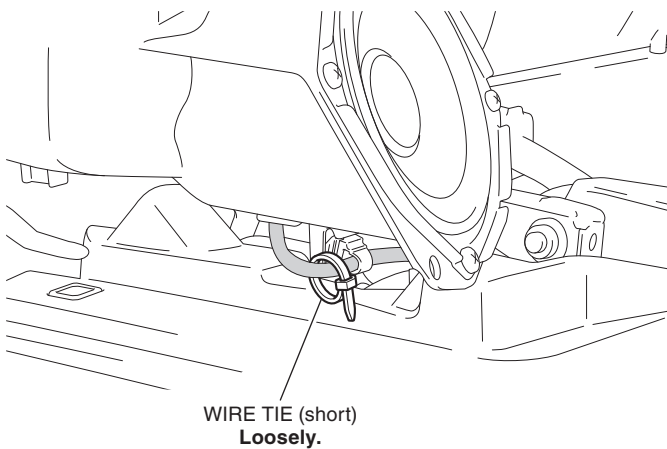

41. Route and secure the CB antenna code as shown.

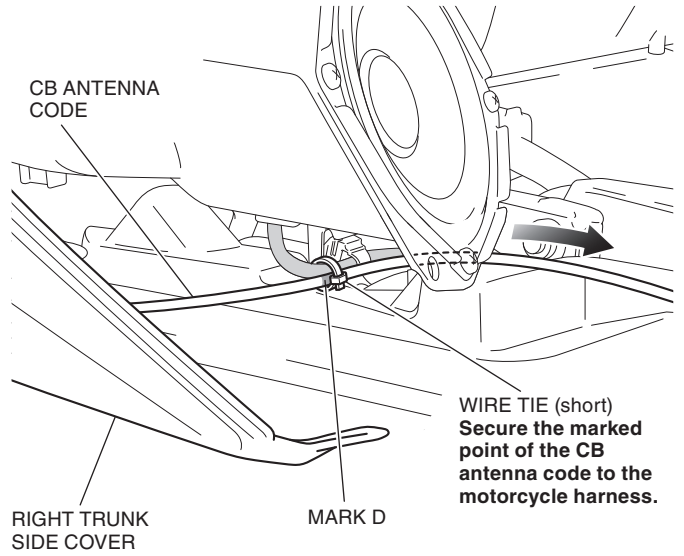

42. Secure the CB antenna code with the wire tie as shown.

<Right side>

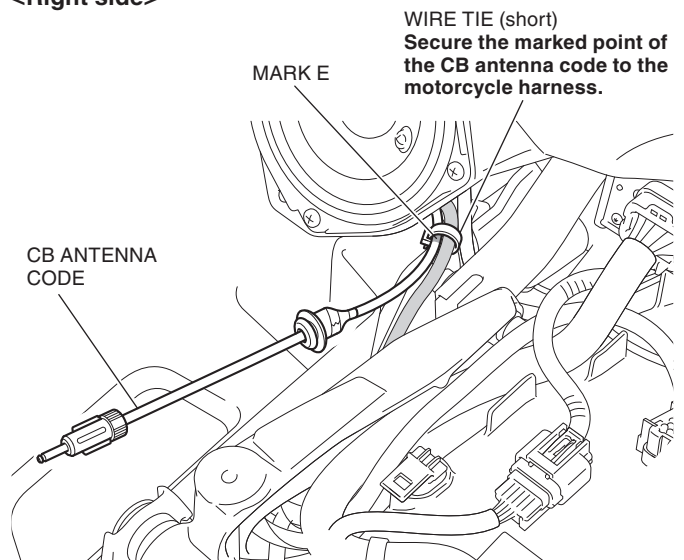

43. Install the right trunk front cover and the right trunk side cover in the reverse order of removal.

44. Apply dish soap solution to the position shown.

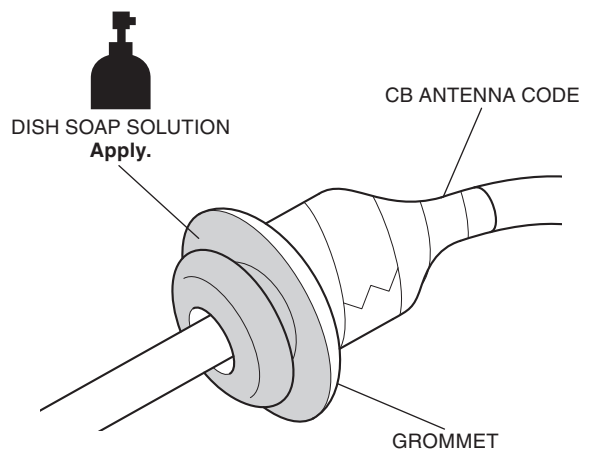

45. Route the CB antenna code as shown.

- Install the CB antenna code, then return the boot to the original position.

<Right side>

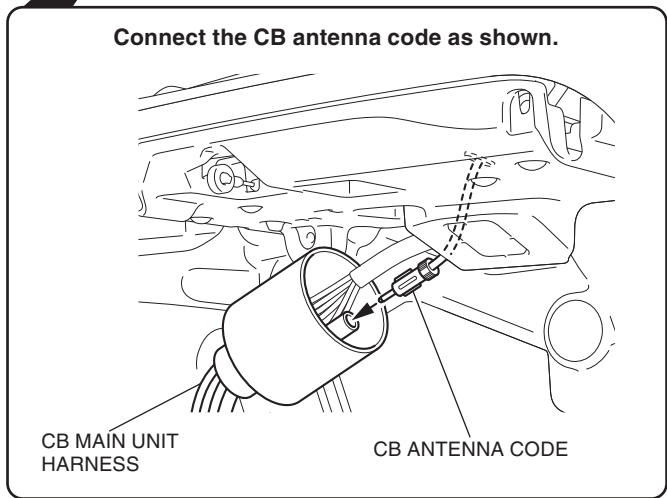
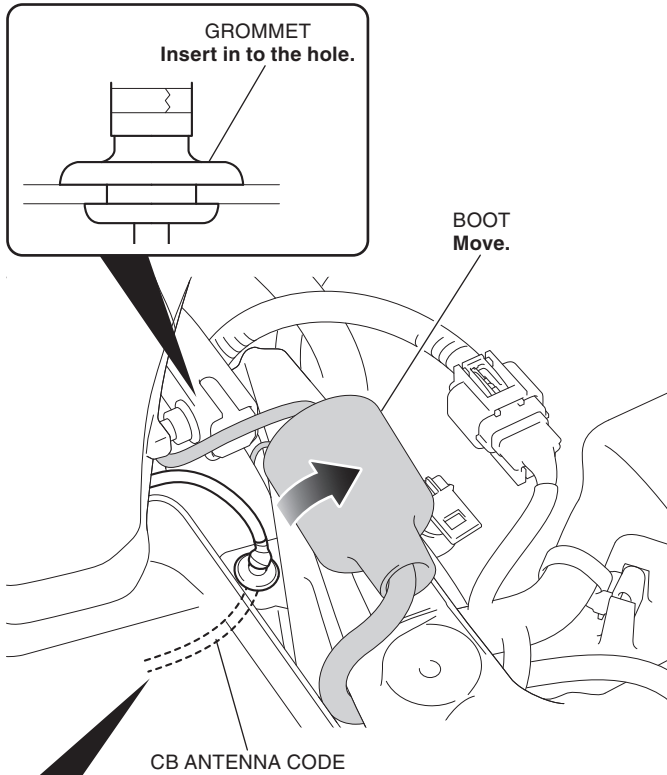

46. Clean the surface of the area shown using isopropyl alcohol.

- Perform this step for both collars.

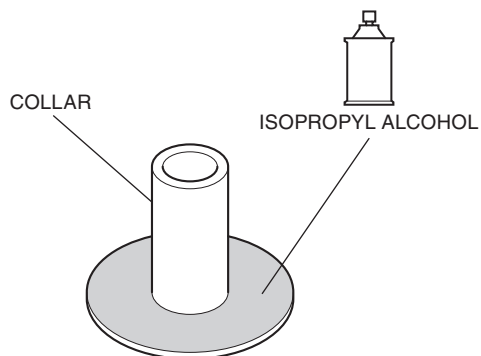

47. Attach the rubber to the collar as shown.

- Perform this step for both rubbers.

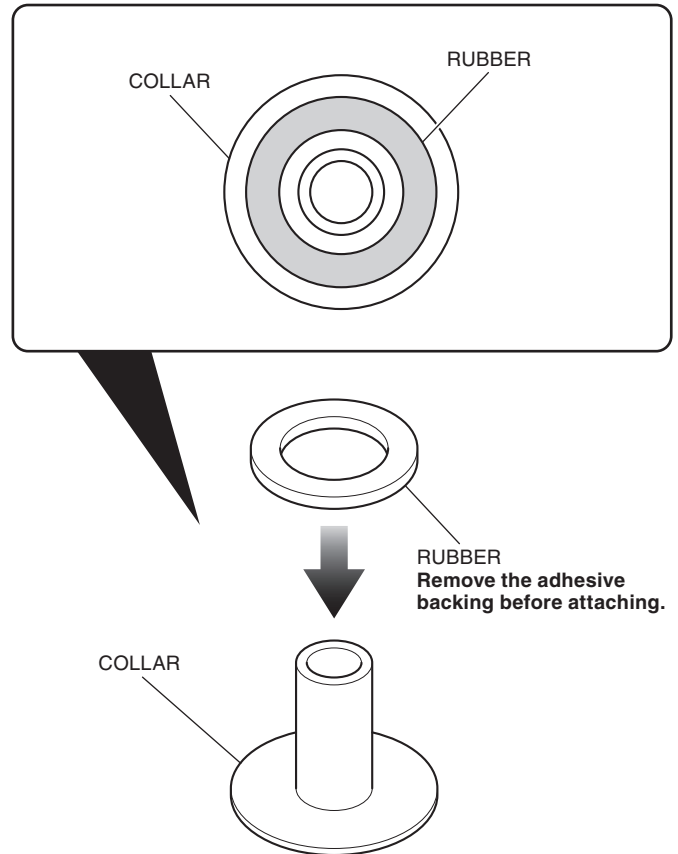

48. Install the collars as shown.

<Right side>

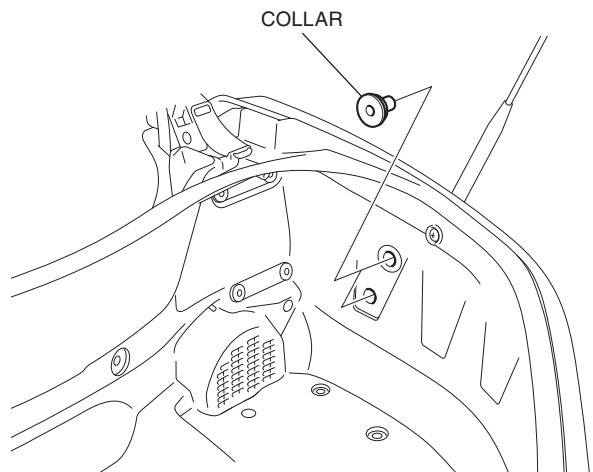

49. Install the CB antenna stay as shown.

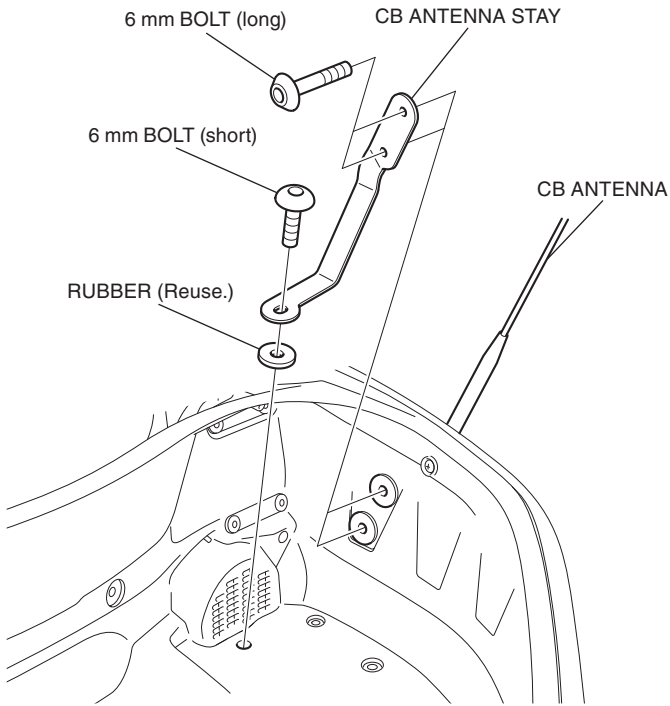

50. Secure the harness boot with the clamp as shown.
<Right side>

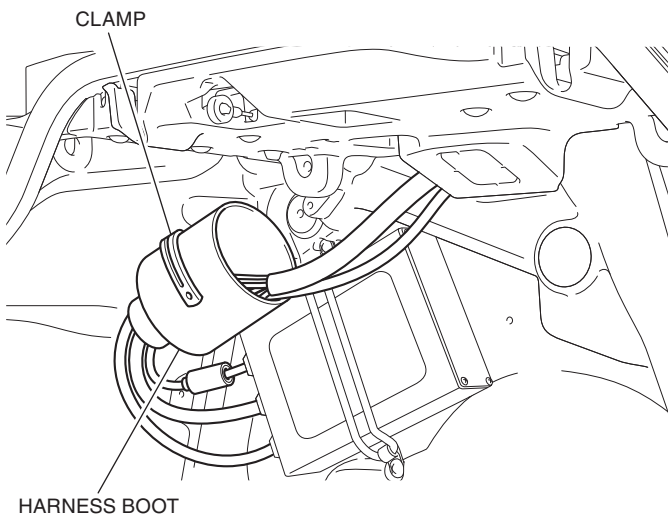

51. Install the right saddlebag catch in the reverse order of removal.

- **Confirm that the wire harness is not caught or too tight.**

52. Install the CB unit cover as shown.

- **Confirm that the wire harness is not caught or too tight.**

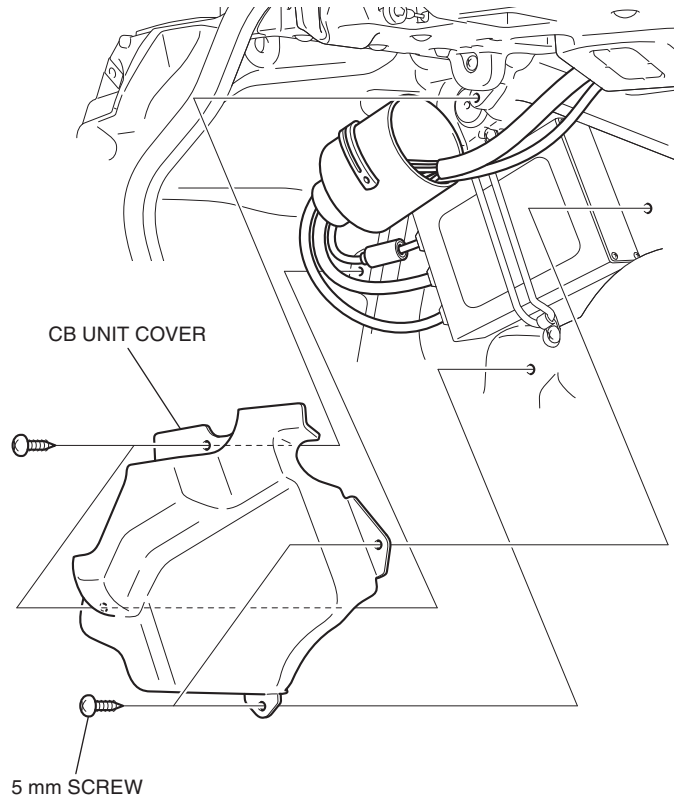

53. Move the boot and remove the dummy connector as shown.

<Right side>

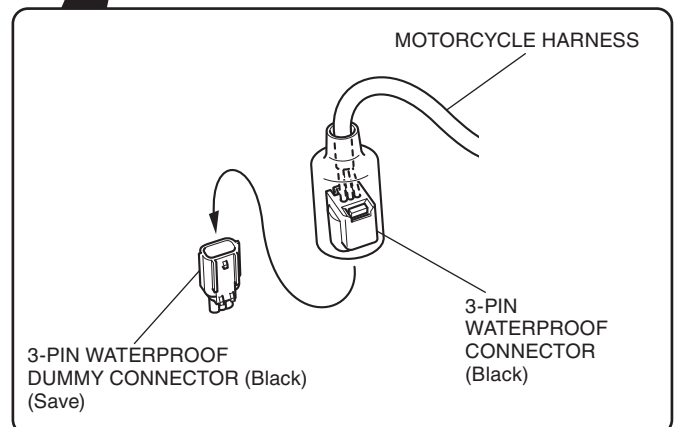
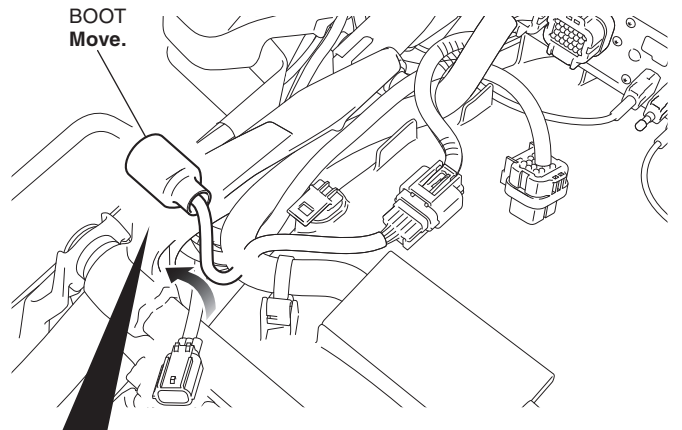

54. Connect the CB radio sub harness as shown.
- **Set the boot to the original position.**

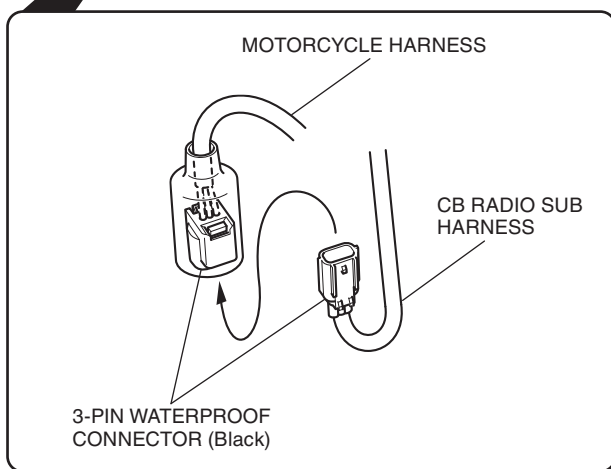
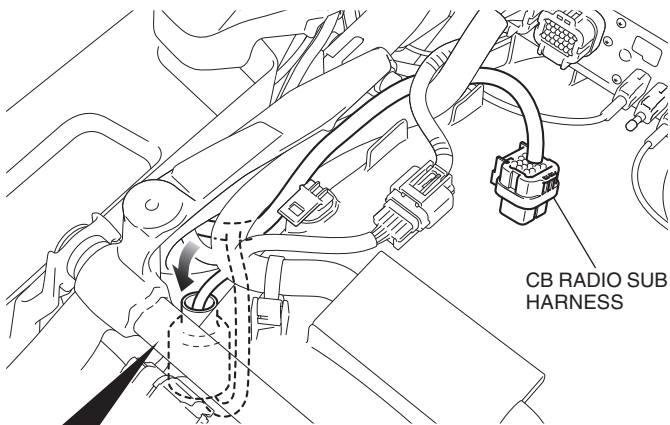

55. Remove the dummy connector as shown.

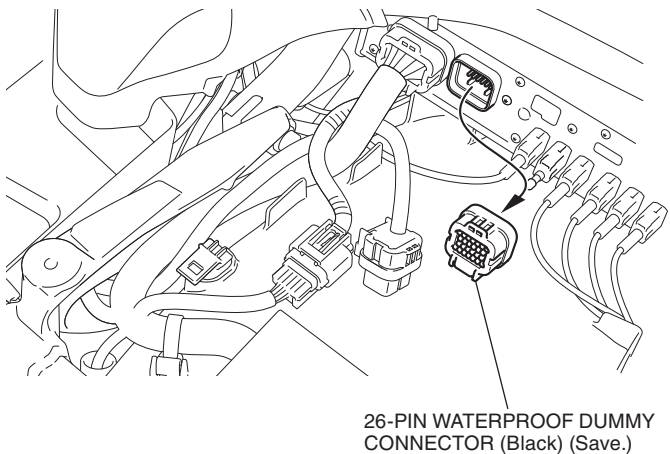

56. Connect the CB radio sub harness as shown.

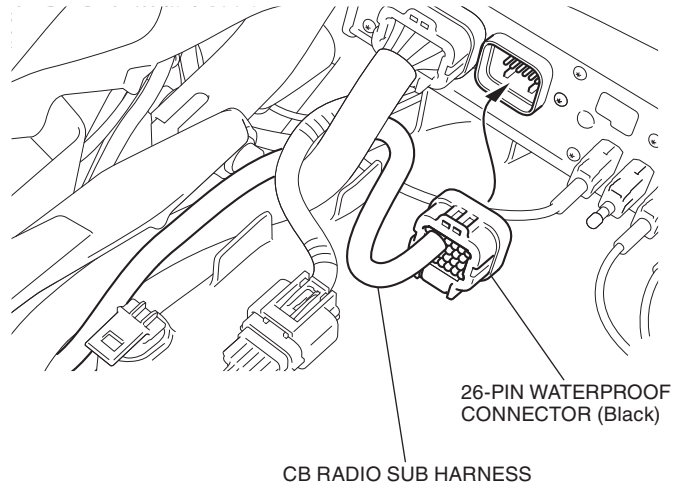

57. Secure the CB radio sub harness with the wire tie as shown.

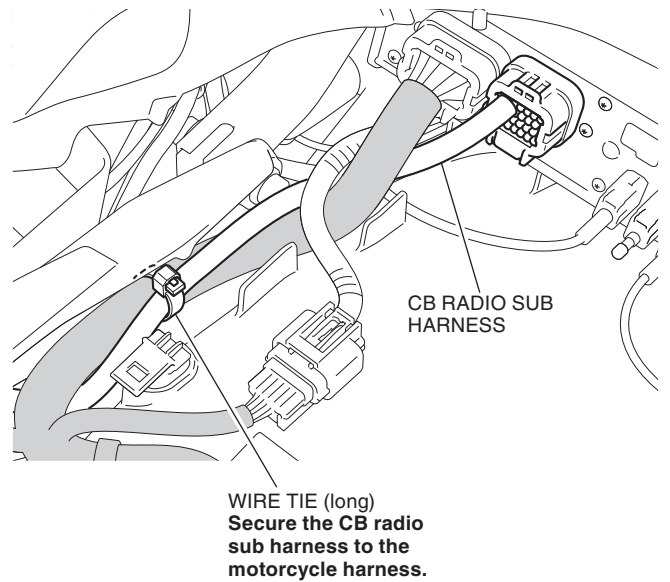

58. Install the connector to the clip in the reverse order of removal.
59. Install the motorcycle parts in the reverse order of removal.
- **Confirm that the wire harness is not caught or too tight.**
60. Check the CB radio, headlight and the other lights for proper operation.