



www.scottoiler.com

Technical Support



technical@scottoiler.com



+44(0)141 955 1100

SA-0074 Triumph Tiger Dispenser Adapter 2011 Models onwards.

Parts List:

M8 x 16 screw



Angled Dispenser Plate

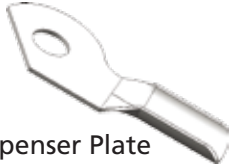

The parts enclosed allow a vSystem or an eSystem to be fitted Triumph Tiger models, 2011 onwards.

For model specific install guides with photographs see www.scottoiler.com

1. Place the Angled dispenser plate supplied in this kit on the recessed bobbin mount with the curved face curving inwards. Align the straight edge with the underside of the swing arm and secure using the M8 screw provided.

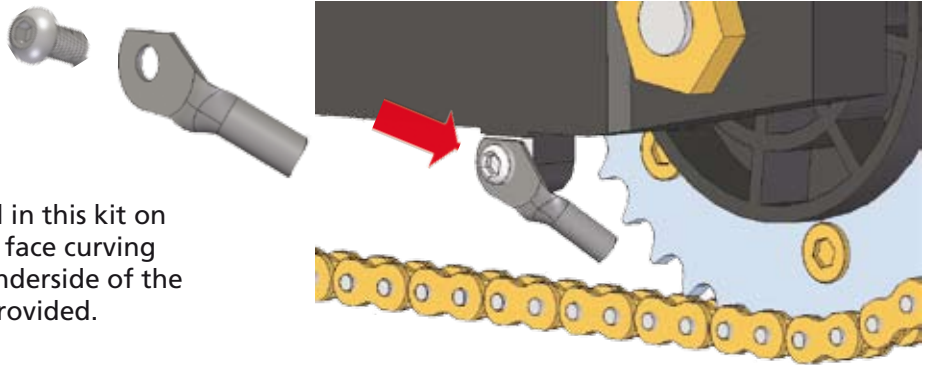

2. Secure the dispenser assembly to the dispenser plate by clamping around the black nylon sleeve using the jubilee clip.

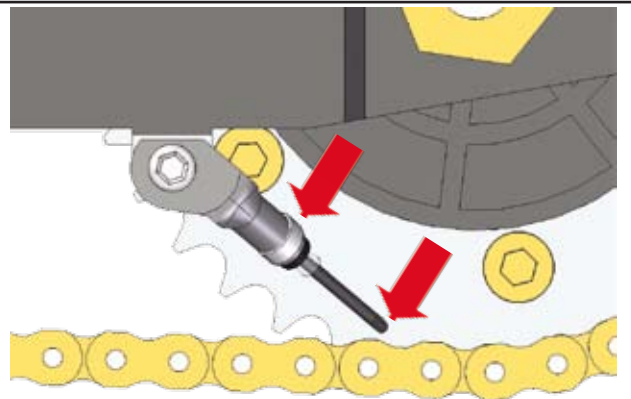

3. Carefully position the nib between the 6 and 8 o'clock position on the outside face of the rear sprocket with the slash cut of the nib facing away from the sprocket. Take care to avoid the sprocket bolts. The metal dispenser plate can be bent towards the sprocket slightly and the nib length altered for optimum fit.

4. Route the delivery tubing from the dispenser back toward the reservoir by routing the delivery tubing inside the swing arm to behind the rear suspension unit and up towards the reservoir on the subframe.

A cable tie can be used to secure the delivery tubing to one coil of the suspension spring.

Make sure delivery tubing is neatly routed, allow a little slack to for suspension movement, and ensure it cannot come loose or be snagged by the chain or other moving parts.

Follow the instructions from either the eSystem or vSystem kit from here.

